

# ALFAPIZZA



## По вопросам продаж и поддержки обращайтесь:

Алматы (7273)495-231  
Ангарск (3955)60-70-56  
Архангельск (8182)63-90-72  
Астрахань (8512)99-46-04  
Барнаул (3852)73-04-60  
Белгород (4722)40-23-64  
Благовещенск (4162)22-76-07  
Брянск (4832)59-03-52  
Владивосток (423)249-28-31  
Владикавказ (8672)28-90-48  
Владимир (4922)49-43-18  
Волгоград (844)278-03-48  
Вологда (8172)26-41-59  
Воронеж (473)204-51-73  
Екатеринбург (343)384-55-89  
Иваново (4932)77-34-06  
Ижевск (3412)26-03-58  
Иркутск (395)279-98-46  
Казань (843)206-01-48

Россия +7(495)268-04-70

Калининград (4012)72-03-81  
Калуга (4842)92-23-67  
Кемерово (3842)65-04-62  
Киров (8332)68-02-04  
Коломна (4966)23-41-49  
Кострома (4942)77-07-48  
Краснодар (861)203-40-90  
Красноярск (391)204-63-61  
Курск (4712)77-13-04  
Курган (3522)50-90-47  
Липецк (4742)52-20-81  
Магнитогорск (3519)55-03-13  
Москва (495)268-04-70  
Мурманск (8152)59-64-93  
Набережные Челны (8552)20-53-41  
Нижний Новгород (831)429-08-12  
Новокузнецк (3843)20-46-81  
Ноябрьск (3496)41-32-12  
Новосибирск (383)227-86-73

Киргизия +996(312)-96-26-47

Омск (3812)21-46-40  
Орел (4862)44-53-42  
Оренбург (3532)37-68-04  
Пенза (8412)22-31-16  
Петрозаводск (8142)55-98-37  
Псков (8112)59-10-37  
Пермь (342)205-81-47  
Ростов-на-Дону (863)308-18-15  
Рязань (4912)46-61-64  
Самара (846)206-03-16  
Саранск (8342)22-96-24  
Санкт-Петербург (812)309-46-40  
Саратов (845)249-38-78  
Севастополь (8692)22-31-93  
Симферополь (3652)67-13-56  
Смоленск (4812)29-41-54  
Сочи (862)225-72-31  
Ставрополь (8652)20-65-13  
Сургут (3462)77-98-35

Казахстан +7(7172)727-132

Сыктывкар (8212)25-95-17  
Тамбов (4752)50-40-97  
Тверь (4822)63-31-35  
Тольятти (8482)63-91-07  
Томск (3822)98-41-53  
Тула (4872)33-79-87  
Тюмень (3452)66-21-18  
Ульяновск (8422)24-23-59  
Улан-Удэ (3012)59-97-51  
Уфа (347)229-48-12  
Хабаровск (4212)92-98-04  
Чебоксары (8352)28-53-07  
Челябинск (351)202-03-61  
Череповец (8202)49-02-64  
Чита (3022)38-34-83  
Якутск (4112)23-90-97  
Ярославль (4852)69-52-93



We cracked the  
code to making  
**great pizza at  
home!**



INDEX

# Table of **content**



p **10-19** 01. Design & Performance

- P. 12-17 Heat Genius™  
P. 18-19 Forninox Technology
- 

p **22-27** 02. Made in Italy

- P. 26-27 Guiding principles
- 

p **28-59** 03. Alfa Forni

- P. 30 Family Design  
P. 32 **MODERNO Line**  
P. 34 Moderno Portable  
P. 42 Moderno Ovens  
P. 46 **CLASSICO Line**  
P. 48 Classico Ovens  
P. 52 **FUTURO Line**  
P. 54 Futuro Ovens  
P. 58 Comparative Table

p **60-75** 04. Accessories & Complements

- P. 62 Multi-functional base  
P. 64 Kit Pizzaiolo  
P. 66 Professional peel set  
P. 68 BBQ 500  
P. 70 Kit Hybrid  
P. 72 Other tools
- 

p **76** 05. Technical Data Sheets

ALFA FORNI

# Mission, Vision & Promise



We want to reach and **inspire people** around the world looking to experience the pleasure of cooking with ovens and **share the taste of life** with their loved ones.



We want to provide professionals and amateurs with **beautiful high-performance ovens proudly Made in Italy with a commitment to quality**, for the best experience and satisfaction.



**Art and performance without any compromise!**



**ALFA**  
WOOD-BURNING STOVE

# 01

## DESIGN & PERFORMANCE

# Alfa cooks **toppings at one temp, crust at another**

### **Why is it so difficult to make great pizza at home?**

Pizza is the world's, and America's, favorite food. Ahead of burgers, steak, chicken. Everything!

Why, then, do people routinely make burgers, steak, and chicken at home, but not pizza?





## The problem is the pizza. **The solution is Alfa.**

Burgers, steak, and chicken are easy to cook correctly. They are one-dimensional foods. Pizza is a two-dimensional food. You've got the dough, which to turn into a crispy crust on the outside that's moist and chewy on the inside, needs to be cooked quickly on a stone at a high temperature. And, you've got the toppings - cheese, sauce, meats and veggies all of which have high moisture content. In order to fully cook them in the same short time it takes to bake the crust, you need an even higher temperature.

Other at-home pizza ovens, especially inexpensive entry-level pizza ovens, are not designed to make this all happen in concert. None of them, that is, except the Alfa Heat Genius™ Pizza Oven.

Alfa has a long history of building commercial pizza ovens, and they've applied this Heat Genius technology to their at-home pizza ovens. Alfa works like the commercial pizza ovens in a restaurant. It gets really hot and maintains the heat far better than other at-home pizza ovens. This means you get a crispy crust that's still moist and chewy, cheese that's melted and toppings that are perfectly cooked.

DESIGN & PERFORMANCE

# Introducing **Heat Genius™**

Alfa's technology trifecta!



## **Authentic HeatKeeper™ Firebrick**

vs ordinary lava stone or ceramic

Alfa uses an authentic firebrick in every pizza oven they make. This HeatKeeper firebrick, which they make in their factory in Rome, Italy, the home of pizza, absorbs and stores heat far better than the lava stone or ceramic used in other pizza ovens. This is crucial to baking a crispy, moist crust at precisely the right temperature, quickly and without burning.

## 02. DoubleDown Ceramic Superwool® Insulation

vs ordinary rock wool insulation (or no insulation at all)

The space between the two stainless steel walls on an Alfa Pizza Oven is filled with DoubleDown Superwool® insulation. This European ceramic fiber offers up to twice the heat resistance of the rock wool insulation used in other artisan at-home pizza ovens, which maintains the heat and allows you to consistently bake perfect pizzas. It also allows for faster heat recovery between pizzas and dramatically lowers the temperature of the outer oven wall.



Superwool® is a registered trademark of Morgan Advanced Materials

## 03. Patented Full Effect Full Circulation Flue System®

vs ordinary “up and out” chimneys



Other pizza ovens exhaust precious heat out the chimney at the top of their oven. Up and out! Not Alfa. The chimney may be at the top, but, thanks to the patented Full Effect Full Circulation Flue System®, hot air circulates fully around the chamber and is driven back down to where it can heat the firebrick and pizza. This is key, as it ensures the proper temperatures required to bake both crust and toppings. The circulating heat then hits a deflector at the top of the oven and travels up an escape where it finally exits out the chimney. Around and down. Then up and out. Clever!

DESIGN E PERFORMANCE

# The art and science of **Pizza baking performance**

Alfa Forni's research and development department patented its **Flue System™ technology** in 2019. A **smoke extraction system that improves the circulation of hot air inside the cooking chamber**, increasing the oven's thermal efficiency.

This patented design helps Alfa Forni use all the heat available, while others lose it. Another reason why **Alfa lets you enjoy your pizza at home just like you would in a pizzeria.**





## Choosing the right size Alfa Pizza Oven



### **Compact** (1 Pizza)

A compact oven has ample space for a good-sized pizza. A full meal would need to be cooked in sequence.



### **Medium** (2 to 3 Pizzas)

A medium size oven has extra space allowing you to cook an additional item simultaneously cutting total cooking time in half.



### **Large** (4 to 5 Pizzas)

A larger oven has the space to cook pizza and an entire meal all at the same time, making ideal for a family.

DESIGN E PERFORMANCE

# Six additional reasons to buy an Alfa Heat Genius™ Pizza Oven.

01.

These ovens are built sturdy!

## **Forninox™ Premium Stainless Steel Chamber Construction**

If you are going to generate high heat you need to withstand high temperatures. The Forninox combustion chamber on an Alfa Pizza Oven is constructed of two different types of special thermal-resistant heavy-gauge steel.

The inner wall is made of a titanium-impregnated 441 stainless that can tolerate thermal stress, is resistant to heat, corrosion and atmospheric agents.

The stainless used for the exterior wall is also heat and acid-resistant as it contains less iron than the steel used in other pizza ovens.

Together, these chamber walls help retain Alfa's heat while also providing for a well-made, very sturdy oven.



02.

Testing reveals the perfect shape for the perfect pizza.

## **OptiDome Half-Sphere Design**

The unique shape of an Alfa Heat Genius Pizza Oven is integral to its performance. The “flattened” half-dome design was developed after extensive testing revealed the shape maximized circulation and heat flow, a phenomenon that leads to quick heat-up as well as consistent temperatures for even cooking.





## 03.

The finish is beautiful and made to last.

### **Double Powder-Coated Oven Shell**

All Alfa Pizza Ovens are double powder-coated using a seven-step powder-coating process that will ensure a durable, long-lasting finish.

## 04.

Our burners push heat across the oven while others blow it out.

### **Premium SideFire Gas Burner**

All gas-powered Alfa Ovens feature a SideFire Burner system in which the burner is located on the side of the oven. This way, the heat is blown across the oven to circulate up and around the combustion chamber. Other brands place their burners in the back of the oven. This means the heat is blown out the door which is, obviously, very inefficient.



## 05.

Heats up much faster than other artisan pizza oven.  
(shorter time between pizzas, too)

### **“Ready Already” Faster To Baking Temperature**

Alfa's Heat Genius™ design not only allows you to bake the perfect pizza, it also allows you to start baking the perfect pizza much sooner. There is nothing more frustrating than having to wait for the pizza oven to heat up when you have hungry pizza-lovers that are ready to eat. Alfa can be ready in as little as 20 minutes, much faster than other artisan pizza ovens!

And, as important, your Alfa Pizza Oven will better-maintain the heat, as well. With other pizza ovens, after removing a baked pizza or pizzas, the vessel will take considerably longer to come back up to proper temperature which, again, causes hungry pizza-lovers to wait.



## 06.

Seamless Shell. (unlike other pizza ovens)

### **Seamless Shell Construction**

Alfa Pizza Ovens are built to last. The oven shell features seamless construction which will last much longer than the riveted shells on other pizza ovens.

DESIGN & PERFORMANCE

# The perfect combination: **Forninox technology**

The innovation of Forninox™ technology consists in **combining the excellent physical and thermal properties of steel with those of refractory brick**, the material used to build professional ovens.

The **steel structure** ensures adequate resistance to the thermal and mechanical stress caused by the high temperatures reached by the oven.

**Insulating the dome** with two layers of ceramic fibre instead allows the temperature to be raised very quickly and held for longer, gradually releasing the heat and achieving optimal cooking.









ALFA





**Italian quality  
and technological  
evolution** in a  
single oven!

02

02

MADE IN ITALY

# Handmade in Italy.

Alfa headquarter is based in **Anagni**, between Roma and Napoli, in the birthplace of pizza.

**Every Alfa Oven is 100% handmade in Italy, by skilled artisans.**

The word "artisan" comes from "art". That's why today more than ever, being an artisan means **combining creativity and skill, energy and passion to create something unique** with your own hands.

Our domestic and professional ovens have been recognized worldwide for their quality and design for more than 45 years.



Every Alfa Oven is  
**100% handmade  
in Italy, by skilled  
artisans.**



MADE IN ITALY

# A family business **since 1977**

Leading a professional team requires leaders who can lead and motivate, who have a clear vision of the future and a keen eye on traditions: **Marcello Ortuso and Rocco Lauro are the founders of Alfa Forni** and the soul of this great, wonderful company.



MADE IN ITALY

# Oven Pioneering

"We imagine a world where the wood fired oven becomes an intuitive device for everybody. We'd like to bring people back to their roots and see one of our flame ovens in every home."



MADE IN ITALY

# Our **guiding principles**

## 01.

### QUEST FOR VALUE FOR CUSTOMERS

We strive to anticipate, understand and meet the needs and expectations of our customers through continuous dialogue, providing highly useful products.

## 02.

### USEFUL INNOVATION

As an Italian company competing on the global market, we have forged an aptitude for innovation based on tradition, design research, continuous renewal and evolutionary drive that benefits our customers and which we intend to pursue.

## 03.

### LEADERSHIP

We seamlessly shape our leadership with strength and tenacity, based on personal example and modesty, trusting people and promoting team spirit to help our employees grow.







## 04. VALUING PEOPLE

As a family company, we are dedicated to the well-being of our employees and their personal development. We promote respect in mutual relations and believe in the value of lasting relationships with customers, suppliers and other industry partners.

## 05. RESPONSIBILITY AND INTEGRITY

The utmost attention is dedicated to workplace safety and to fairness and integrity in conduct amongst ourselves, our business partners and the general public.

## 06. LONG-TERM ORIENTATION

44 years after its foundation, the generational changeover with the inclusion of the second generation in top positions guarantees continuity and long-term orientation. Our harmonious and resilient strategic development are based on prudence and financial soundness.

## 03

ALFA FORNI

In the  
beginning it  
was the oven.  
**Now there's  
Alfa.**

The **pioneering** nature of our roots, the resilience we have built up in the face of change and our internationality have guided us on our journey of **growth**.

**Alfa Ovens are designed and conceived as professional ovens.** With their unique and patented design, our ovens **guarantee excellent cooking performance** thanks to innovative materials and technologies.



ALFA FORNI

# Family DESIGN

To define who we are, we like to start from an **absolute principle**, which for us is quality given by constant innovation, the selection of exclusively Italian materials and **attention to detail**.

Alfa ovens for domestic use are **uniquely designed products, suitable for classic and modern environments**, for gardens and terraces.



MODERNO Line

**CLASSICO** Line



**FUTURO** Line



ALFA FORNI

## MODERNO Line

The MODERNO Line was designed to enhance the beauty of the design and performance of Alfa ovens while maintaining the characteristic lines that distinguish them. Perfect for those who have many friends with whom to share the taste of Italian cuisine.

Alfa ovens are the most satisfying **outdoor cooking experience**.

Every technical feature of Alfa's stainless ovens is designed to improve your life.

Starting with the speed of ignition and cooking precision: they quickly heat up to 500°C and can cook a pizza in 1 minute.









ALFA



“The new **Portable  
Pizza Oven** by Alfa”

MODERNO Line

# Portable

**A true Neapolitan Pizza Oven, that marries technology and design in only 35 Kg.**

The new Moderno Portable is compact and lightweight (Only 35 Kg) and thanks to the available carry bag cover can be transported anywhere you desire. Easy to assemble - just insert the flue and chimney cowl and let the party begin.



Dimensions: 55 x 53 x 91h cm

details



focus





## Technical specifications

**External dimensions:**

Top: 55 x 53 x 91h cm

**Cooking Floor:**

40cmx40cm

**Fuel:**

Gas only (LPG version)

**Consumption:**

0,50 kg/h

**Available in:**



**Maximum temperature:**

500°C

**Capacity:**

1 Pizza

**Weight:**

35 Kg

**Colours\*:**



Ardesia Grey



Antique Red

\*Alfa Colour Table at page 76



ALFA



SEI FA  
IN QUATTRO  
PER UNDECI  
**FELICE**  
E' UNA  
PIZZA

## Moderno 1 Pizza

With its unmistakable Alfa design the Moderno 1 Pizza oven is compact and weights only 50 Kg.

**Colors:**

Antique Red ● Ardesia Grey ●

**Heatkeeper Refractory Floor:**

Wood 60 x 40 cm | Gas 50 x 40 cm

**Fuel:** Wood or Gas

**Hybrid Kit Accessory:** Available



Dimensions: 73 x 55 x 105h cm



## Moderno 2 Pizze

Functional design and attention to detail combined with the best of Alfa technology make the 2 Pizze oven an exceptionally high-performance cooking tool that blends perfectly in modern outdoor spaces.

**Colors:**

Antique Red ● Ardesia Grey ●

**Heatkeeper Refractory Floor:**

Wood 70 x 50 cm | Gas 60 x 50 cm

**Fuel:** Wood or Gas

**Hybrid Kit Accessory:** Available



Dimensions: 95 x 70 x 105,5 h cm





## Moderno 3 Pizze

The new Moderno 3 Pizza oven with increased capacity is an oven that is ready to cook the first pizza in just 30 minutes.

**Colors:**

Antique Red ● Ardesia Grey ● Fire Yellow ●

**Heatkeeper Refractory Floor:**

Wood 90 x 50 cm | Gas 80 x 50 cm

**Fuel:** Wood or Gas

**Hybrid Kit Accessory:** Available



Dimensions: 108 x 73 x 114h cm



## Moderno 5 Pizze

Moderno 5 Pizze is the largest Alfa oven and is designed for those who want to cook like the pros with capacity to feed a crowd. Plus, it has beauty to enhance any outdoor setting.

**Colors:**

Antique Red ● Ardesia Grey ● Fire Yellow ●

**Heatkeeper Refractory Floor:**

Wood 100 x 70 cm | Gas 85 x 70 cm

**Fuel:** Wood or Gas

**Hybrid Kit Accessory:** Available



Dimensions: 118 x 102 x 149h cm









ALFA FORNI

# CLASSICO Line

**Alfa's CLASSICO line is a clever combination of traditional lines and technological innovation.**

Soft but elaborate curves to embellish any space. An artisan oven perfect for elegant villas and gardens.

**The unique patented design** of our ovens ensures a **comfortable and elegant cooking experience**, whether in an outdoor kitchen or in the garden, thanks to materials and technologies that promote excellent resistance to moisture and efficient thermal insulation.





“Our **compact stainless steel oven** designed for cooking pizza and more”

## Classico 2 Pizze

Perfect for small backyards, balconies or anywhere space is at a premium.

**Colors:**

Ardesia Grey ●

**Heatkeeper Refractory Floor:**

Wood 70 x 50 cm | Gas 60 x 50 cm

**Fuel:** Wood or Gas

**Hybrid Kit Accessory:** Available

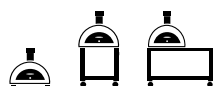

Dimensions: 95 x 75 x 109h cm

## Classico 4 Pizze

The new Classico 4 Pizze with increased capacity can cook up to 4 pizzas and much more.

**Colors:**

Ardesia Grey ●

**Heatkeeper Refractory Floor:**

Wood 90 x 60 cm | Gas 80 x 60 cm

**Fuel:** Wood or Gas

**Hybrid Kit Accessory:** Available

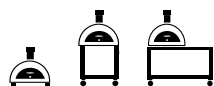

Dimensions: 108 x 91 x 115,7h cm







CLASSICO



ALFA FORNI

# FUTURO Line

**Alfa's FUTURO line is specially designed for outdoor kitchens.** The design, structure and front in stainless steel make it ideal to pair with your grill or other cooking equipment.

Alfa Ovens's evolution lies in the design, innovation and **versatility** of its ovens.

The FUTURO line **allows all types of cooking** and thanks to its capacity, it's ideal for the whole family to eat in little time.





“The **hybrid oven** that’s designed for outdoor kitchens”

## Futuro 2 Pizze

The design and stainless-steel front make the Futuro 2 Pizze ideal to pair with your grill and other outdoor kitchen equipment.

**Colors:**

Silver Black ●

**Heatkeeper Refractory Floor:**

70 x 40 cm

**Fuel:** Gas only

**Hybrid Kit Accessory:** Available



Dimensions: 100 x 63.8 x 123h cm

## Futuro 4 Pizze

Our top of the line oven for the serious outdoor kitchen. The large capacity Futuro 4 Pizze is a semiprofessional pizza oven designed to fit harmoniously in any outdoor kitchen.

**Colors:**

Silver Black ●

**Heatkeeper Refractory Floor:**

80 x 60 cm

**Fuel:** Gas only

**Hybrid Kit Accessory:** Available



Dimensions: 110 x 84 x 151h cm







The **future of pizza**  
made just like in a  
pizzeria!





Comparative table



	CLASSICO Line		FUTURO Line	
	2 Pizze	4 Pizze	2 Pizze	4 Pizze
<b>Dimensions</b>	95x75x109h cm	108x91x115,7h cm	100x63.8x123h cm	110x84x151h cm
<b>Cooking Floor</b>	70x50 cm WOOD 60x50 cm GAS	90x60 cm WOOD 80x60 cm GAS	70x40 cm GAS	80x60 cm GAS
<b>Pizza capacity</b>	2 Pizzas	4 Pizzas	2 Pizzas	4 Pizzas
<b>Weight</b>	86 kg	118 kg	110 kg	142 kg
<b>Fuel</b>	Wood or Gas (Hybrid with kit)	Wood or Gas (Hybrid with kit)	Gas (Hybrid with kit)	Gas (Hybrid with kit)
<b>Combinations</b>				
<b>Colors</b>				



	MODERNO Line				
	Portable	1 Pizza	2 Pizze	3 Pizze	5 Pizze
<b>Dimensions</b>	55x53x91h cm	73x55x105h cm	95x70x105,5h cm	108x73x114h cm	118x102x149h cm
<b>Cooking Floor</b>	40x40 cm GAS	60x40 cm WOOD 50x40 cm GAS	70x50 cm WOOD 60x50 cm GAS	90x50 cm WOOD 80x50 cm GAS	100x70 cm WOOD 85x70 cm GAS
<b>Pizza capacity</b>	1 Pizza	1 Pizza	2 Pizzas	3 Pizzas	5 Pizzas
<b>Weight</b>	35 kg	54 kg	79 kg	97 kg	175 kg
<b>Fuel</b>	Gas	Wood or Gas (Hybrid with kit)	Wood or Gas (Hybrid with kit)	Wood or Gas (Hybrid with kit)	Wood or Gas (Hybrid with kit)
<b>Combinations</b>					
<b>Colors</b>					

# 04

## ACCESSORIES AND COMPLEMENTS

# The **tools** of the trade.

To get the most out of your wood-fired oven, Alfa Forni has put together a complete catalogue of accessories to make preparing and cooking food easier, letting you serve dishes full of flavour and tradition.

Alfa accessories will ensure that you **always have the right tools at the right time**. All the tools in the Kits are certified for food use and selected according to the highest quality standards.





ACCESSORIES & COMPLEMENTS

# Multi-functional **base**

Multi-functional pizza base that serves as a **station for preparing pizzas** and as a **base** for ALFA top ovens.

Available in the following versions: 100 cm - 130 cm - 160 cm.

\*The 130 and 160 cm models include a cylinder cover bulkhead and two umbrella holes.

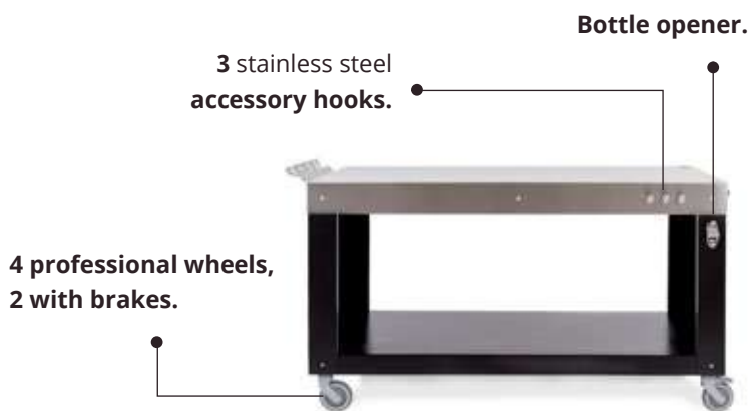

# Details



Protect your oven  
with **Alfa Covers!**





ACCESSORIES & COMPLEMENTS

# Kit Pizzaiolo

The Kit Pizzaiolo includes **all the tools you need to prepare and roll out pizza dough, bake and serve it.**

**1 RAKE PEEL**

The **ember rake** lets you manage the cooking floor. Use it to move ash, embers and wood safely.

**2 TURNER PEEL**

The **turner peel** is used to turn pizzas while they are cooking.

**3 BRUSH PEEL**

The **brush peel** has brass bristles that make cleaning the refractory surface more effective without scratching it.

**4 PIZZA PEEL**

Peel for putting uncooked pizza in the oven, with holes to allow excess flour to fall out.

**5 WOODEN CUTTING BOARD**

The **wooden cutting board made of food-grade spruce** allows you to follow the grooves to cut pizzas into equal parts.

**6 LASER THERMOMETER**

The **infrared thermometer** makes it easy to read the temperature at every point of the cooking surface

**7 OVEN MITT**

**Heat resistant glove** in continuous-filament, 100% cotton bouclé yarn.

**8 BREAD SPATULAS**

Asymmetrical peel for easily gripping bread.

**9 PIZZA CUTTER**

Pizza cutting wheel with an ergonomic handle and removable steel blade.

**10 ALFA APRON**

With the ALFA apron, everyone will know that **you're the chef.**

**11 COOKBOOK**

Lots of **recipes for your wood-burning oven.** Developed by the chefs of the Alfa team.

**12 PIZZA DOUGH BOX**

The box ensures the proper air conditions for the **dough rising process.**



ACCESSORIES & COMPLEMENTS

# Professional **peel set**

The new pizza peels **designed by Alfa** are the result of more than a year's research by the R&D team: **all the peels can be unscrewed and screwed together** if necessary using universal extensions, starting from 95 cm up to the desired length.





**RAKE PEEL**

**Ember rake:** made of stainless steel, it lets you safely move ash, embers and burning wood.

**TURNER PEEL**

**Turner peel:** light, robust and handy, it is used to turn pizzas while they cook.

**BRUSH PEEL**

**Brush peel:** brass bristles that make cleaning the refractory surface more effective without scratching it.

**PERFORATED PEEL**

**Peel for putting uncooked pizza in the oven,** with holes to allow excess flour to fall out.

**HANDLES AND EXTENSIONS**

Anodised aluminium tubular handles and duroplast grips.

# Details



## Medium Pizza Peel

A set of Alfa design professional pizza peels ideal for the most compact ovens of the Alfa range, which includes a convenient medium pizza peel and a pizza turning peel.



ACCESSORIES & COMPLEMENTS

## BBQ 500

With “BBQ 500”, your Alfa oven becomes a barbecue with the power and control to cook with a flame and embers, up to 500°C, in both gas and wood-fired ovens.

Available in the following versions: 30 cm - 37 cm.

**Rotating grill:** allows you to adjust the cooking time, moving food with a simple gesture.

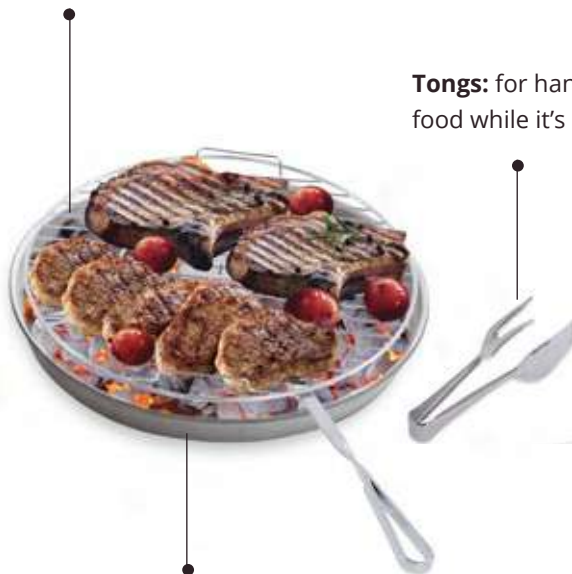

**Tongs:** for handling food while it's cooking.

**Tray:** sized to the grill to protect the cooking surface, ideal for melting excess fat during cooking.



# Details

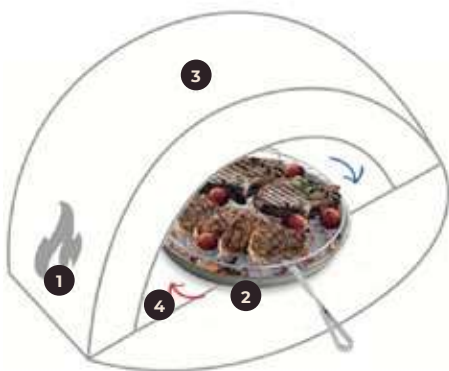

## 4 heat sources!

- 1 Open flame
- 2 Hot embers
- 3 Enveloping dome
- 4 Hot brick



ACCESSORIES & COMPLEMENTS

## Kit Hybrid

The Alfa Forni patented kit makes it possible to **use your gas oven with wood:** cover the burner on the left with the special burner lid to protect it from soot and the heat of the flame, and use the wood guard on the right to keep the wood on the side.

**WOOD HOLDER:**

It contains the firebox, passing the proper amount of air for combustion and keeps the cooking surface clean.



**BURNER LID**

A special lid for the gas burner, which prevents damaging the gas supply system when using the oven with wood.



Details

## Alfa **Wood holder**

**The advantages** of using the Alfa wood holder are:

- Quick and easy flame ignition thanks to the increased passage of air under the wood.
- Easy cleaning during use of the wood-burning oven
- Functional and elegant design, with perforated Alfa logo.
- Made of high-quality steel.
- Available in 37 or 59 cm versions.



## Dado peel holder

Complete your outdoor area dedicated to pizza with the Dado pizza peel holder. A practical, functional, but also elegant and stylish tool.



## Vela peel holder

In addition to being convenient and functional, the Vela peel holder is an accessory with a refined and innovative shape that perfectly adapts to the interior and exterior of your home.



## Topping station

Your best ally for to organise ingredients and to season pizzas. Let yourself be surprised by the Alfa topping station, an essential accessory for the perfect preparation of your pizzas.



## **Wood** Pizza Peel

Alfa wooden pizza peels are made entirely of natural beech from sustainable forests. They are not chemically treated and no glues are used. Alfa wooden pizza peels are available in three different sizes: 32, 36, 40 cm.



## **Pastry** board

The traditional pastry board, for the impeccable stretching out of pizza dough. The Alfa pastry board in laminated fir wood represents the ideal fusion between tradition and functionality.



## **Baking** tray set

Bake your pizzas in a pan, cook your roasts and potatoes or prepare your favourite cakes with Alfa baking trays.

## Low & Slow Kit



The LOW & SLOW kit is ideal for bread-making or cooking at low temperatures. Thanks to the glass window, you can always keep an eye on your food and, thanks to the butterfly valve keep low temperature under control.

## Rocker cutter



With the Rocker cutter – the Alfa mezzaluna pizza cutter – making portions for all your guests will be quick and easy.

## Pizza Dough Box



The dough ball box guarantees the proper air conditions and maximum hygiene for the rising process. Suitable for any home refrigerator.





## **Infrared** Thermometer

The infrared thermometer allows you to read the temperature on all points of the oven floor in order to bake at the right time.



## **Recipe** book

Lots of recipes and precious suggestions on how to use your wood-fired or gas-fuelled oven and get the very best from your Alfa domestic oven.



## **Gas** Connector

Alfa has created the first gas regulator with quick coupling and cylinder level indicator that is easy to install, safe and certified.

05

TECHNICAL INFORMATION

Index

**Technical  
Data Sheets**

p **78**    **Alfa Colour Table**  
Domestic Ovens

---

p **80**    Technical Data Sheet  
**MODERNO Portable**

---

p **82**    Technical Data Sheet  
**MODERNO 1 Pizza**

---

p **86**    Technical Data Sheet  
**MODERNO 2 Pizze**

---

p **90**    Technical Data Sheet  
**MODERNO 3 Pizze**

---

p **94**    Technical Data Sheet  
**MODERNO 5 Pizze**

---

p **98**    Technical Data Sheet  
**CLASSICO 2 Pizze**

---

p **102**    Technical Data Sheet  
**CLASSICO 4 Pizze**

---

p **106**    Technical Data Sheet  
**FUTURO 2 Pizze**

---

p **108**    Comparative table  
**FUTURO Pizze**

---

TECHNICAL INFORMATION

# Colours Table

## Domestic Ovens



Silver Black



Antique Red



Ardesia Gray



Fire Yellow

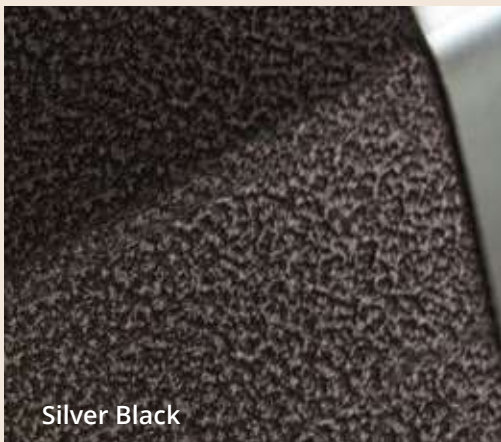

Silver Black



Antique Red



Ardesia Gray



Fire Yellow

# Moderno Portable

Data Sheets - Scheda Tecnica



**ANTIQUE RED**  
FXMD-PT-GROA

**ARDESIA GREY**  
FXMD-PT-GGRA

<b>Weight</b> Peso	<b>35 kg</b> <b>77 lbs</b>	<b>Materials</b> Materiali	<b>Stainless Steel, iron sheet, Ceramic fiber</b> Acciaio inox, lamiera ferro, Fibrocera mica
<b>Cooking floor</b> Piano Cottura	<b>40 x 40 cm</b> <b>16 x 16 in</b>	<b>Type of refractory</b> Tipo di refrattario	<b>Alumina silicate HeatKeeper™ Firebrick</b> Tavella HeatKeeper™ silico-alluminoso
<b>Max oven temperature</b> Temperatura massima	<b>500°C</b> <b>1000°F</b>	<b>Recommended fuel</b> Combustibile consigliato	<b>LPG gas (G30 / G31)</b> Gas GPL (G30 / G31)
<b>Heating time</b> Minuti per scaldare	<b>30'</b>	<b>Gas category</b> Categoria gas	<b>I3+ GPL</b>
<b>Pizza capacity</b> Numero Pizze	<b>1 Pizza</b> Ø33cm	<b>G30 / G31 operation</b> Funzionamento a G30 / G31	<b>28..30 / 37 mbar</b> 11 in WC
<b>Heat capacity</b> Potenza nominale	<b>7 kW</b>	<b>Max consumption</b> Consumo Massimo	<b>0.5 kg/h</b>



*made in Italy*

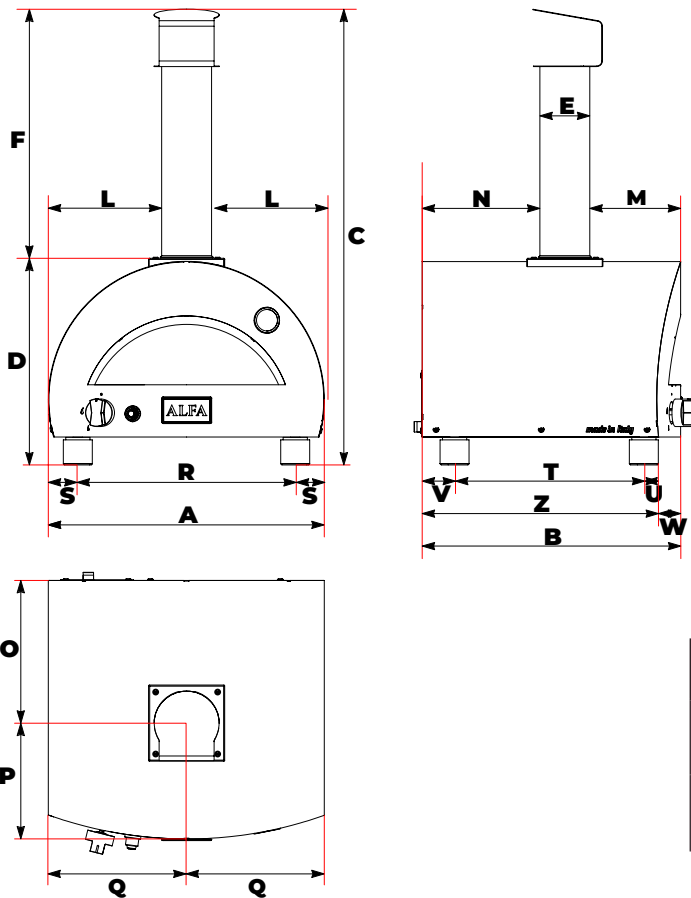

<b>A</b>	<b>55 cm</b> 21.7 in	<b>O</b>	<b>28.6 cm</b> 11.2 in
<b>B</b>	<b>51.7 cm</b> 20.4 in	<b>P</b>	<b>23.5 cm</b> 9.3 in
<b>C</b>	<b>91.2 cm</b> 35.9 in	<b>Q</b>	<b>27.7 cm</b> 10.9 in
<b>D</b>	<b>41.3 cm</b> 16.3 in	<b>R</b>	<b>43.5 cm</b> 17.1 in
<b>E</b>	<b>∅ 10 cm</b> 3.9 in	<b>S</b>	<b>5.8 cm</b> 2.3 in
<b>F</b>	<b>49.9 cm</b> 19.6 in	<b>T</b>	<b>37.9 cm</b> 14.9 in
<b>G</b>	<b>36.8 cm</b> 14.5 in	<b>U</b>	<b>2.7 cm</b> 1.1 in
<b>H</b>	<b>12 cm</b> 4.7 in	<b>V</b>	<b>6.9 cm</b> 2.6 in
<b>L</b>	<b>22.7 cm</b> 8.9 in	<b>W</b>	<b>4.5 cm</b> 1.8 in
<b>M</b>	<b>18.2 cm</b> 7.2 in	<b>Z</b>	<b>47.3 cm</b> 18.6 in
<b>N</b>	<b>23.6 cm</b> 9.3 in		

PACKAGING DIMENSIONE IMBALLO			
Width Larghezza	Depth Profondità	Height Altezza	Weight Peso
<b>55 cm</b> 21.6 in	<b>58 cm</b> 22.8 in	<b>38 cm</b> 15 in	<b>40 Kg</b> 88 lbs

Description Descrizione	Code Codice
<b>Chimney cap</b> Comignolo	<b>A</b> CMG-2-015
<b>Chimney</b> Canna fumaria	<b>B</b> TI100-430-SAT
<b>KIT GAS 24kW</b>	<b>C</b> GAS-1-015
<b>Side gas cover</b> Carter laterale gas	<b>D</b> CRT-2-035
<b>Gas knob</b> Manopola gas	<b>E</b> D14MANO-MC55
<b>Electric generator</b> Generatore elettrico	<b>F</b> GENELP003IQ
<b>Electrical cable</b> Cavo elettrico	<b>F</b> D14CAVOTV-1000
<b>Door</b> Sportello	<b>G</b> SPT-1-013
<b>Flange</b> Flangia	<b>H</b> FLG-2-015
<b>External shell</b> Carter esterno	<b>I</b> CRT-1-019
<b>Thermometer</b> Termometro	<b>J</b> D14TERM-5070
<b>Red bricks 40x20 cm</b> Mattoni 40x20 cm	<b>K</b> RRA4020
<b>Board</b>	<b>L</b> BOARD 10
<b>Feet (n.4)</b> Piedini	<b>M</b> SETPIE-M10X25
<b>Logo Alfa (v1.0)</b>	<b>N</b> D14PLAC-ALFA

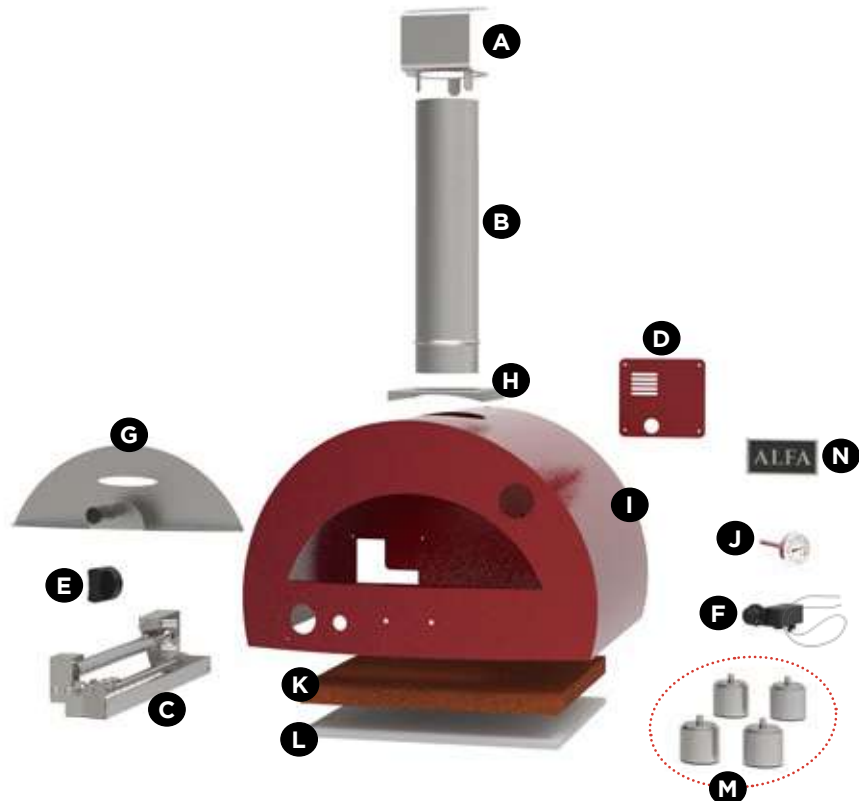

# Moderno 1 Pizza

Data Sheets - Scheda Tecnica



**ANTIQUE RED**  
FXMD-1P-LROA

**ARDESIA GREY**  
FXMD-1P-LGRA

<b>Weight</b> Peso	<b>54 kg</b> <b>119 lbs</b>	<b>Materials</b> Materiali	<b>Stainless Steel, iron sheet, Ceramic fiber</b> Acciaio inox, lamiera ferro, Fibroceramica
<b>Cooking floor</b> Piano Cottura	<b>60x50 cm</b> <b>24 x 16 in</b>	<b>Type of refractory</b> Tipo di refrattario	<b>Alumina silicate HeatKeeper™ Firebrick</b> Tavella HeatKeeper™ silico-alluminoso
<b>Max oven temperature</b> Temperatura massima	<b>500°C</b> <b>1000°F</b>	<b>Recommended fuel</b> Combustibile consigliato	<b>WOOD - Max 2 in diam. logs. trimmings</b> LEGNA - Ciochi diametro Max 5 cm potature
<b>Heating time</b> Minuti per scaldare	<b>30'</b>	<b>Minimum flue draught</b> Tiraggio minimo	<b>10 Pa</b>
<b>Pizza capacity</b> Numero Pizze	<b>1</b> Ø30cm	<b>Flue smokes mass flow</b> Flusso volumetrico fumi	<b>57.7 g/s</b>
<b>Rated charge</b> Carica Nominale	<b>6.9 kg/h</b> 15,2 lbs/h	<b>Average consumption</b> Consumo Medio	<b>2.5 kg/h</b> 5.5 lbs/h
<b>Smoke temperature</b> Temperatura fumi	<b>395°C</b> 743°F	<b>CO emission at 13% O<sub>2</sub></b> Emissioni CO al 13% O <sub>2</sub>	<b>0.31% 3843 mg/Nm<sup>3</sup></b>



*made in Italy*



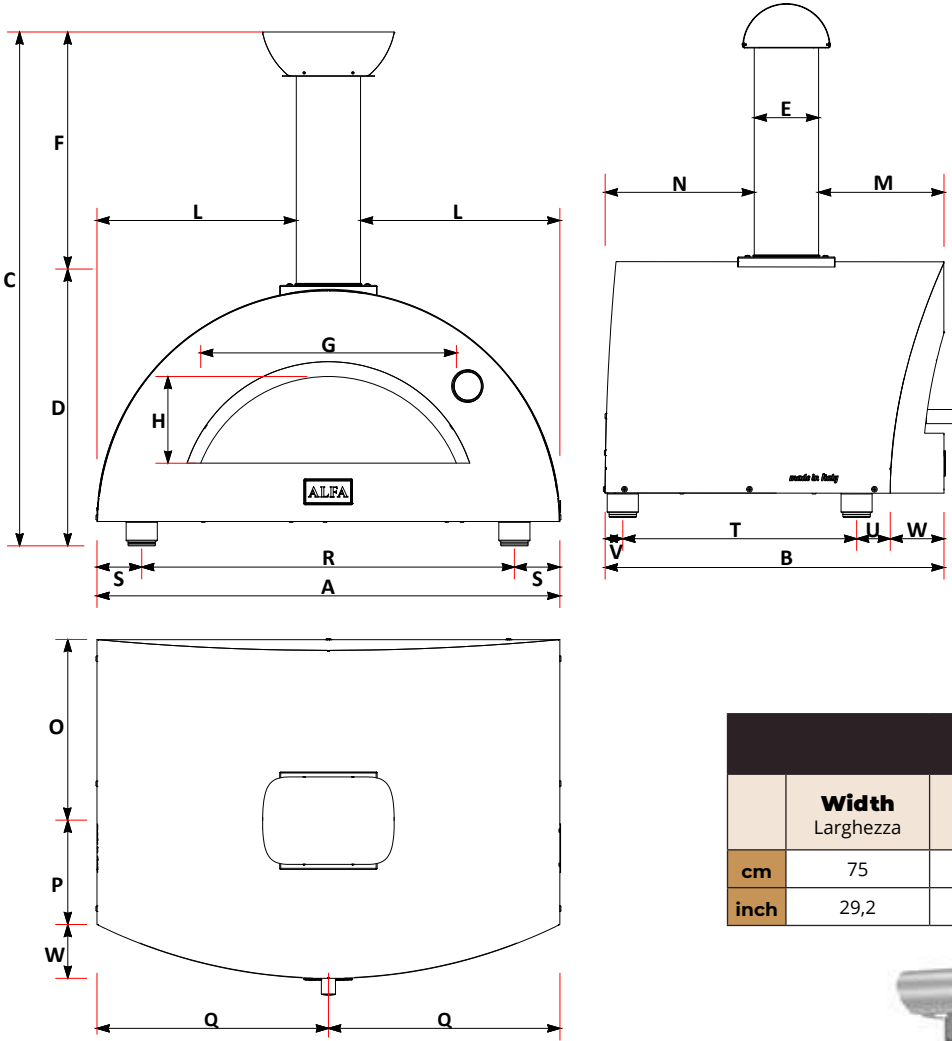

	cm	inch		cm	inch
A	74	29,1	N	22,9	9,0
B	54,75	21,6	O	29,4	11,6
C	105	41,3	P	25,4	10,0
D	47,8	18,8	Q	36,6	14,4
E	13	5,1	R	64,1	25,2
F	57,2	22,5	S	4,5	1,8
G	37,3	14,7	T	38,3	15,1
H	14,5	5,7	U	3,3	1,3
L	30,1	11,9	V	4,9	1,9
M	18,8	7,4	W	8,2	3,2

PACKAGING				
DIMENSIONE IMBALLO				
	Width Larghezza	Depth Profondità	Height Altezza	Weight Peso
cm	75	58	46	kg 57
inch	29,2	22,6	17,9	lbs 125,4

Description Descrizione	Code Codice
<b>Chimney cap</b> Comignolo	<b>A</b> SML-03-0221
<b>Chimney</b> Canna fumaria	<b>B</b> TI130_500_SAT
<b>Door</b> Sportello	<b>C</b> SSML-03-0224
<b>Flange</b> Flangia	<b>D</b> SML-03-0220
<b>External shell</b> Carter esterno	<b>E</b> CRT-1-013
<b>Thermometer</b> Termometro	<b>F</b> YT63-135
<b>Red bricks 30x20 cm</b> Mattoni 30x20 cm	<b>G</b> RRA3020
<b>Feet (n.4)</b> Piedini	<b>H</b> SETPIE-M10X20
<b>Logo Alfa (v1.0)</b>	<b>I</b> D14PLAC-ALFA
<b>Wood holder</b> Paralegna	<b>L</b> SML-03-0222



# Moderno 1 Pizza

Data Sheets - Scheda Tecnica



**ANTIQUE RED**  
FXMD-1P-GROA

**ARDESIA GREY**  
FXMD-1P-GGRA

<b>Weight</b> Peso	<b>56 kg</b> <b>124 lbs</b>	<b>Materials</b> Materiali	<b>Stainless Steel, iron sheet, Ceramic fiber</b> Acciaio inox, lamiera ferro, Fibroceramica	
<b>Cooking floor</b> Piano Cottura	<b>50x40 cm</b> <b>20 x 16 in</b>	<b>Type of refractory</b> Tipo di refrattario	<b>Alumina silicate HeatKeeper™ Firebrick</b> Tavella HeatKeeper™ silico-alluminoso	
<b>Max oven temperature</b> Temperatura massima	<b>500°C</b> <b>1000°F</b>	<b>Recommended fuel</b> Combustibile consigliato	<b>LPG gas (G30 / G31)</b> Gas GPL (G30 / G31)	<b>Natural Gas (G20)</b> Gas Metano (G20)
<b>Heating time</b> Minuti per scaldare	<b>30'</b>	<b>Gas category</b> Categoria gas	<b>I3+ GPL</b>	<b>I2H (METANO)</b>
<b>Pizza capacity</b> Numero Pizze	<b>1</b> Ø30cm	<b>Operation</b> Funzionamento	<b>28..30 / 37 mbar</b> 11 in WC	<b>20 mbar</b> 4 in WC
<b>Heat capacity</b> Potenza nominale	<b>8 kW</b> 27280 BTU/h	<b>Max consumption</b> Consumo Massimo	<b>0.58 kg/h</b>	<b>1.43 m³/h</b>



*made in Italy*

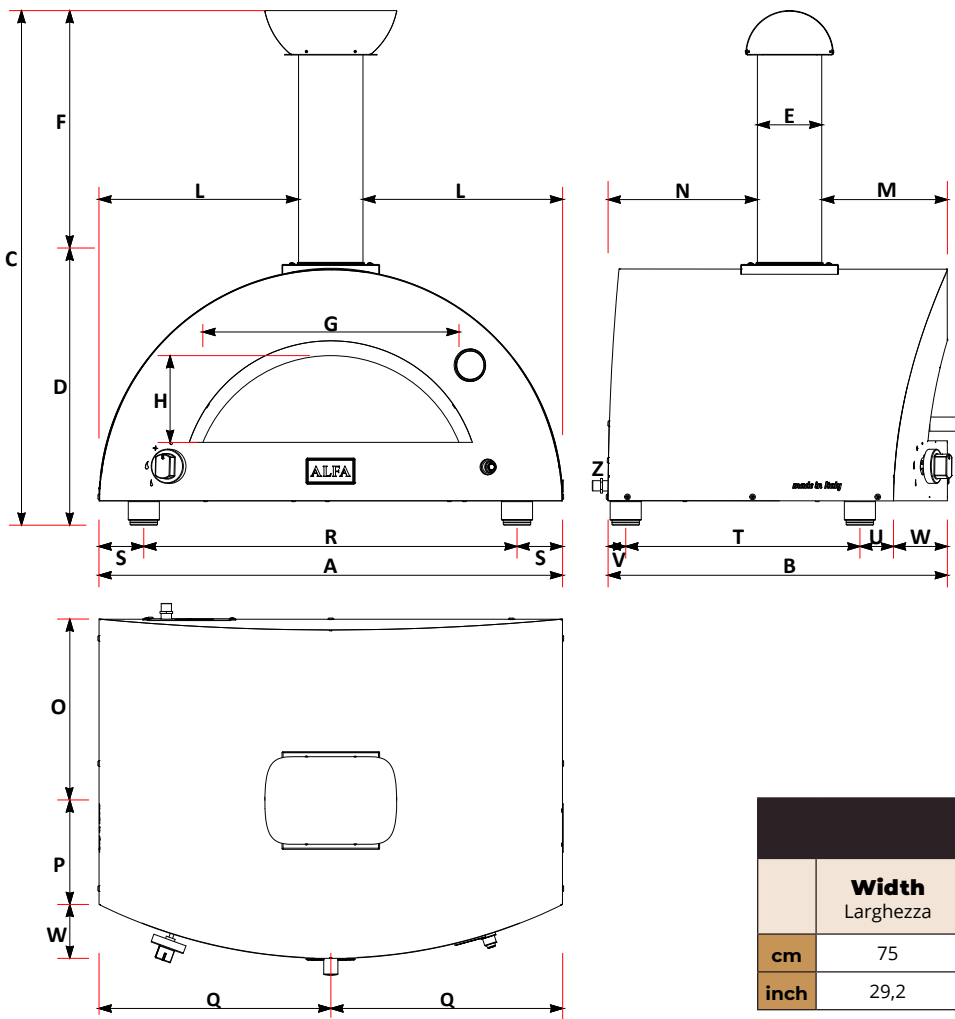

	cm	inch		cm	inch
A	74	29,1	N	22,9	9,0
B	54,75	21,6	O	29,4	11,6
C	105	41,3	P	25,4	10,0
D	47,8	18,8	Q	36,6	14,4
E	13	5,1	R	64,1	25,2
F	57,2	22,5	S	4,5	1,8
G	37,3	14,7	T	38,3	15,1
H	14,5	5,7	U	3,3	1,3
L	30,1	11,9	V	4,9	1,9
M	18,8	7,4	W	8,2	3,2

A minimum of 10 cm (4 in) must be considered to connect the oven to the gas source.  
 Z E' necessario prevedere un minimo di 10 cm per collegare il forno al gas.

PACKAGING				
DIMENSIONE IMBALLO				
	Width	Depth	Height	Weight
	Larghezza	Profondità	Altezza	Peso
cm	75	58	46	kg 59
inch	29,2	22,6	17,9	lbs 130

Description		Code
Descrizione		Codice
<b>Chimney cap</b> Comignolo	<b>A</b>	CGM-2-003
<b>Chimney</b> Canna fumaria	<b>B</b>	TI130_480_SAT
<b>Door</b> Sportello	<b>C</b>	SML-1-001
<b>Flange</b> Flangia	<b>D</b>	FLG-2-011
<b>External shell</b> Carter esterno	<b>E</b>	CRT-1-015
<b>Thermometer</b> Termometro	<b>F</b>	YT63-135
<b>Red bricks 30x20 cm</b> Mattoni 30x20 cm	<b>G</b>	RRA3020
<b>Red bricks 40x20 cm</b> Mattoni 40x20 cm		RRA4020
<b>Feet (n.4)</b> Piedini	<b>H</b>	SETPIE-M10X20
<b>Logo Alfa (v1.0)</b>	<b>I</b>	D14PLAC-ALFA
<b>KIT GAS 24kW</b>	<b>L</b>	GAS-1-011
<b>Gas knob</b> Manopola gas	<b>M</b>	D14MANO-70P
<b>Electric generator</b> Generatore elettrico	<b>N</b>	GENELP003IQ
<b>Electrical cable</b> Cavo elettrico	<b>N</b>	D14CAVOTV-1500
<b>Side gas cover</b> Carter laterale gas	<b>O</b>	CRT-2-015



# Moderno 2 Pizze

Data Sheets - Scheda Tecnica



**ANTIQUE RED**  
FXMD-2-LROA

**ARDESIA GREY**  
FXMD-2-LGRA

<b>Weight</b> Peso	<b>79 kg</b> <b>174 lbs</b>	<b>Materials</b> Materiali	<b>Stainless Steel, iron sheet, Ceramic fiber</b> Acciaio inox, lamiera ferro, Fibroceramica
<b>Cooking floor</b> Piano Cottura	<b>70x50 cm</b> <b>28 x 20 in</b>	<b>Type of refractory</b> Tipo di refrattario	<b>Alumina silicate HeatKeeper™ Firebrick</b> Tavella HeatKeeper™ silico-alluminoso
<b>Max oven temperature</b> Temperatura massima	<b>500°C</b> <b>1000°F</b>	<b>Recommended fuel</b> Combustibile consigliato	<b>WOOD - Max 2 in diam. logs. trimmings</b> LEGNA - Ciochi diametro Max 5 cm potature
<b>Heating time</b> Minuti per scaldare	<b>30'</b>	<b>Minimum flue draught</b> Tiraggio minimo	<b>10 Pa</b>
<b>Pizza capacity</b> Numero Pizze	<b>2 Pizza</b> Ø30cm	<b>Flue smokes mass flow</b> Flusso volumetrico fumi	<b>57.7 g/s</b>
<b>Rated charge</b> Carica Nominale	<b>6.9 kg/h</b> 15,2 lbs/h	<b>Average consumption</b> Consumo Medio	<b>1.6 kg/h</b> 3.5 lbs/h
<b>Smoke temperature</b> Temperatura fumi	<b>395°C</b> 743°F	<b>CO emission at 13% O<sub>2</sub></b> Emissioni CO al 13% O <sub>2</sub>	<b>0.31% 3843 mg/Nm<sup>3</sup></b>



*made in Italy*

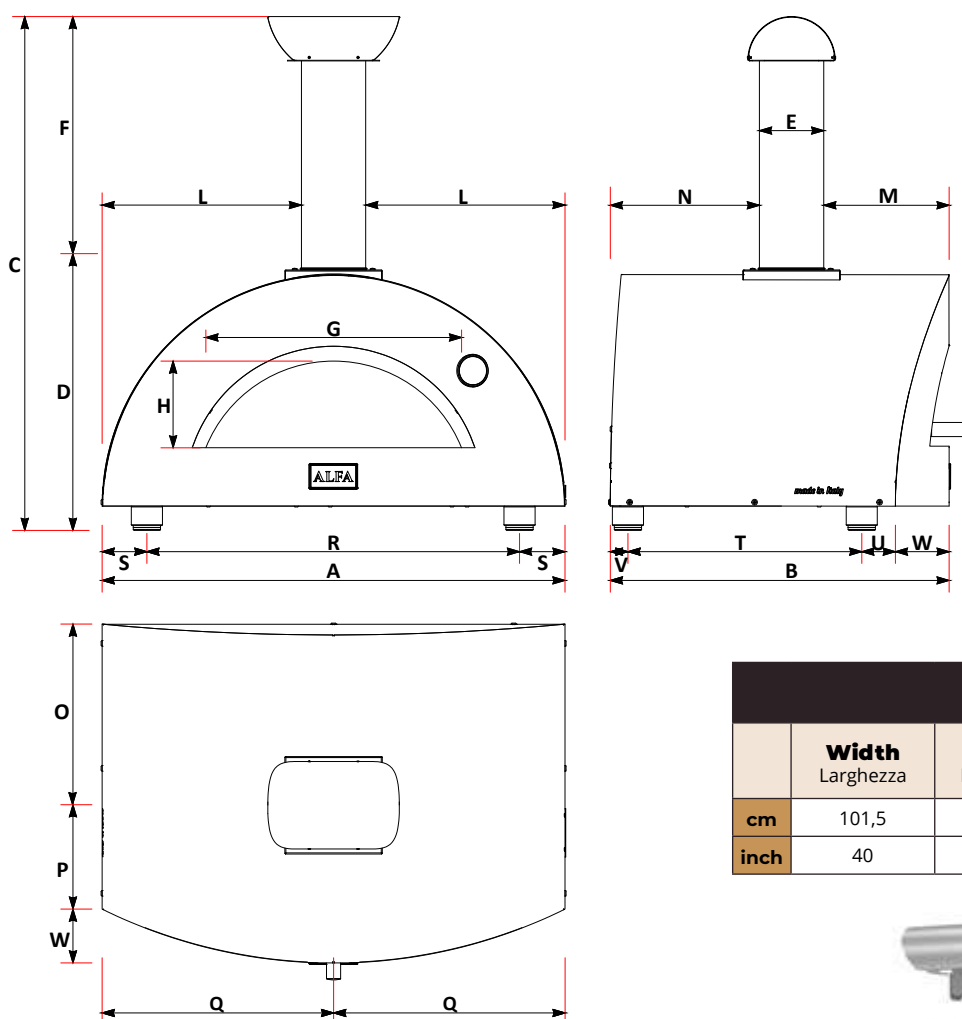

	cm	inch		cm	inch
A	95	37,4	N	30,7	12,1
B	70	27,5	O	36,9	14,5
C	105,5	41,5	P	21,6	8,5
D	48,5	19,1	Q	47,5	18,7
E	13,2	5,2	R	76,5	30,1
F	52	20,5	S	9,2	3,6
G	52,5	20,7	T	48	18,9
H	17,85	7,0	U	6,9	2,7
L	40,1	15,8	V	3,6	1,4
M	25,75	10,1	W	11	4,3

PACKAGING DIMENSIONE IMBALLO					
	Width Larghezza	Depth Profondità	Height Altezza	Weight Peso	
cm	101,5	86	68,5	kg	89
inch	40	34	27	lbs	196

Description Descrizione	Code Codice
<b>Chimney cap</b> Comignolo	<b>A</b> CMG-1-009
<b>Chimney</b> Canna fumaria	<b>B</b> TI130_480_SAT
<b>Door</b> Sportello	<b>C</b> SPT-1-015
<b>Flange</b> Flangia	<b>D</b> FLG-2-009
<b>External shell</b> Carter esterno	<b>E</b> CRT-1-006
<b>Thermometer</b> Termometro	<b>F</b> YT63-135
<b>Red bricks 30x20 cm</b> Mattoni 30x20 cm	<b>G</b> RRA3020
<b>Feet (n.4)</b> Piedini	<b>H</b> SETPIE-M10X20
<b>Logo Alfa (v1.0)</b>	<b>I</b> D14PLAC-ALFA



# Moderno 2 Pizze

Data Sheets - Scheda Tecnica



## ANTIQUE RED

FXMD-2-GROA

## ARDESIA GREY

FXMD-2-GGRA

<b>Weight</b> Peso	<b>79 kg</b> <b>174 lbs</b>	<b>Materials</b> Materiali	<b>Stainless Steel, iron sheet, Ceramic fiber</b> Acciaio inox, lamiera ferro, Fibroceramica	
<b>Cooking floor</b> Piano Cottura	<b>60x50 cm</b> <b>24 x 20 in</b>	<b>Type of refractory</b> Tipo di refrattario	<b>Alumina silicate HeatKeeper™ Firebrick</b> Tavella HeatKeeper™ silico-alluminoso	
<b>Max oven temperature</b> Temperatura massima	<b>500°C</b> <b>1000°F</b>	<b>Recommended fuel</b> Combustibile consigliato	<b>LPG gas (G30 / G31)</b> Gas GPL (G30 / G31)	<b>Natural Gas (G20)</b> Gas Metano (G20)
<b>Heating time</b> Minuti per scaldare	<b>30'</b>	<b>Gas category</b> Categoria gas	<b>I3+ GPL</b>	<b>I2H (METANO)</b>
<b>Pizza capacity</b> Numero Pizze	<b>2 Pizza</b> Ø30cm	<b>Operation</b> Funzionamento	<b>28..30 / 37 mbar</b> 11 in WC	<b>20 mbar</b> 4 in WC
<b>Heat capacity</b> Potenza nominale	<b>15 kW</b> 51.182 BTU/h	<b>Max consumption</b> Consumo Massimo	<b>0.96 kg/h</b>	<b>1.54 m³/h</b>



*made in Italy*

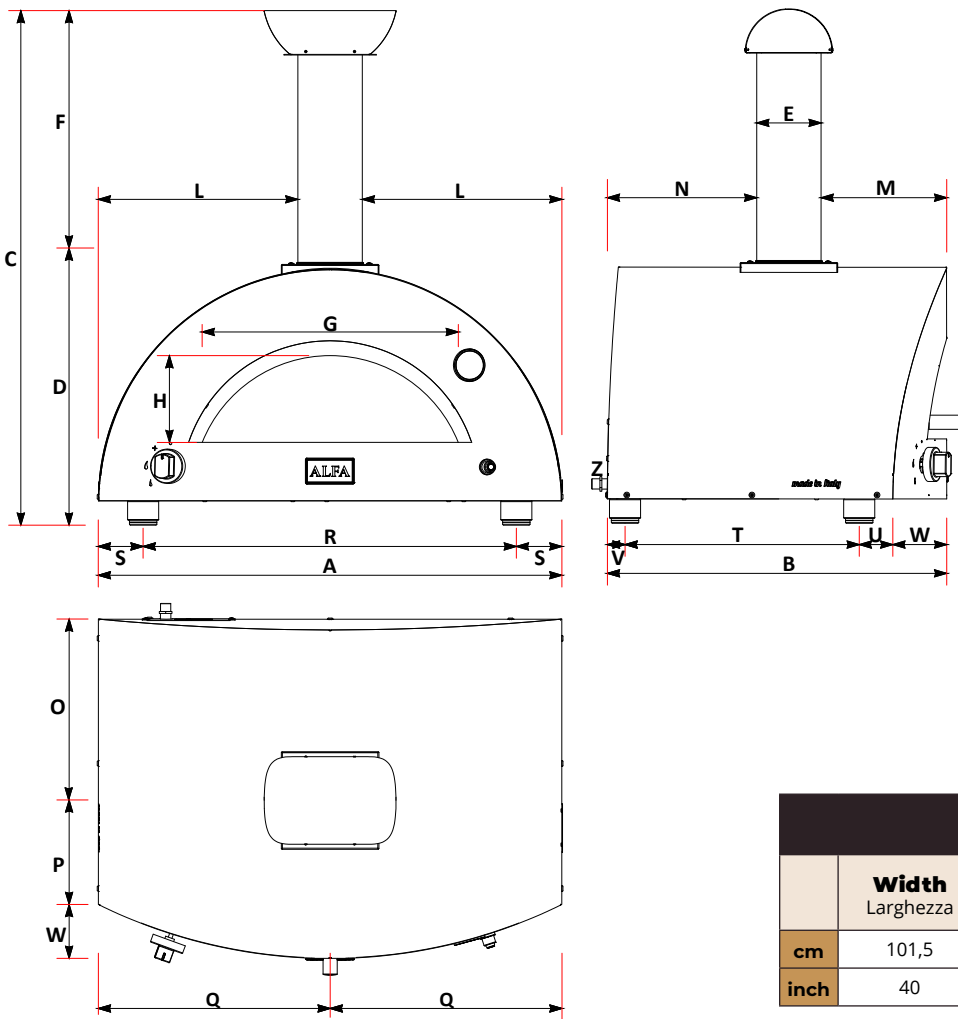

	cm	inch		cm	inch
<b>A</b>	95	37,4	<b>N</b>	30,7	12,1
<b>B</b>	70	27,5	<b>O</b>	36,9	14,5
<b>C</b>	105,5	41,5	<b>P</b>	21,6	8,5
<b>D</b>	48,5	19,1	<b>Q</b>	47,5	18,7
<b>E</b>	13,2	5,2	<b>R</b>	76,5	30,1
<b>F</b>	52	20,5	<b>S</b>	9,2	3,6
<b>G</b>	52,5	20,7	<b>T</b>	48	18,9
<b>H</b>	17,85	7,0	<b>U</b>	6,9	2,7
<b>L</b>	40,1	15,8	<b>V</b>	3,6	1,4
<b>M</b>	25,75	10,1	<b>W</b>	11	4,3

**Z** A minimum of 10 cm (4 in) must be considered to connect the oven to the gas source.  
 E' necessario prevedere un minimo di 10 cm per collegare il forno al gas.

PACKAGING DIMENSIONE IMBALLO					
	Width Larghezza	Depth Profondità	Height Altezza	Weight Peso	
<b>cm</b>	101,5	86	68,5	<b>kg</b>	89
<b>inch</b>	40	34	27	<b>lbs</b>	196

Description Descrizione	Code Codice
<b>Chimney cap</b> Comignolo	<b>A</b> CMG-1-009
<b>Chimney</b> Canna fumaria	<b>B</b> TI130_480_SAT
<b>Door</b> Sportello	<b>C</b> SPT-1-015
<b>Flange</b> Flangia	<b>D</b> FLG-2-009
<b>External shell</b> Carter esterno	<b>E</b> CRT-1-003
<b>Thermometer</b> Termometro	<b>F</b> YT63-135
<b>Red bricks 30x20 cm</b> Mattoni 30x20 cm	<b>G</b> RRA3020
<b>Feet (n.4)</b> Piedini	<b>H</b> SETPIE-M10X20
<b>Logo Alfa (v1.0)</b>	<b>I</b> D14PLAC-ALFA
<b>KIT GAS 24kW</b>	<b>L</b> GAS-1-009
<b>Gas knob</b> Manopola gas	<b>M</b> D14MANO-70P
<b>Electric generator</b> Generatore elettrico	<b>N</b> GENELP003IQ
<b>Electrical cable</b> Cavo elettrico	<b>N</b> D14CAVOTV-1500
<b>Side gas cover</b> Carter laterale gas	<b>O</b> CRT-2-076



# Moderno 3 Pizze

Data Sheets - Scheda Tecnica



**ANTIQUE RED**  
FXMD-3-LROA

**ARDESIA GREY**  
FXMD-3-LGRA

**FIRE YELLOW**  
FXMD-3-LGIA

<b>Weight</b> Peso	<b>97 kg</b> <b>214 lbs</b>	<b>Materials</b> Materiali	<b>Stainless Steel, iron sheet, Ceramic fiber</b> Acciaio inox, lamiera ferro, Fibroceramica
<b>Cooking floor</b> Piano Cottura	<b>90x50 cm</b> <b>35 x 20 in</b>	<b>Type of refractory</b> Tipo di refrattario	<b>Alumina silicate HeatKeeper™ Firebrick</b> Tavella HeatKeeper™ silico-alluminoso
<b>Max oven temperature</b> Temperatura massima	<b>500°C</b> <b>1000°F</b>	<b>Recommended fuel</b> Combustibile consigliato	<b>WOOD - Max 2 in diam. logs. trimmings</b> LEGNA - Cocchi diametro Max 5 cm potature
<b>Heating time</b> Minuti per scaldare	<b>30'</b>	<b>Minimum flue draught</b> Tiraggio minimo	<b>11 Pa</b>
<b>Pizza capacity</b> Numero Pizze	<b>3 Pizza</b> Ø30cm	<b>Flue smokes mass flow</b> Flusso volumetrico fumi	<b>49.6 g/s</b>
<b>Rated charge</b> Carica Nominale	<b>8.3 kg/h</b> 18.3 lbs/h	<b>Average consumption</b> Consumo Medio	<b>2 kg/h</b> 4.4 lbs/h
<b>Smoke temperature</b> Temperatura fumi	<b>395°C</b> 743°F	<b>CO emission at 13% O<sub>2</sub></b> Emissioni CO al 13% O <sub>2</sub>	<b>0.35% 4444 mg/Nm<sup>3</sup></b>



*made in Italy*



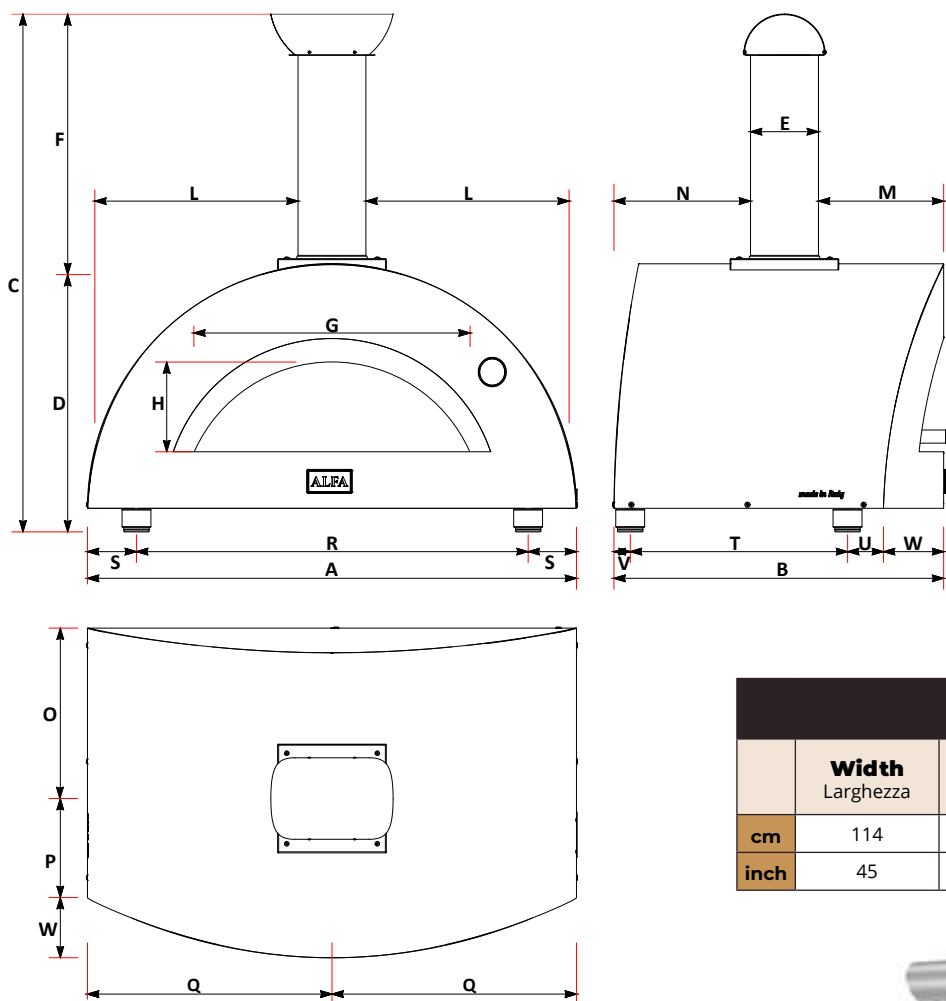

	cm	inch		cm	inch
<b>A</b>	108	42,5	<b>N</b>	30,1	11,9
<b>B</b>	72,8	28,7	<b>O</b>	37,6	14,8
<b>C</b>	114	44,9	<b>P</b>	21,9	8,6
<b>D</b>	60,3	23,7	<b>Q</b>	54	21,3
<b>E</b>	15	5,9	<b>R</b>	86,5	34,1
<b>F</b>	54	21,3	<b>S</b>	10,8	4,3
<b>G</b>	61	24,0	<b>T</b>	48	18,9
<b>H</b>	20	7,9	<b>U</b>	7,95	3,1
<b>L</b>	46,5	18,3	<b>V</b>	3,5	1,4
<b>M</b>	27,7	10,9	<b>W</b>	13,3	5,2

PACKAGING				
DIMENSIONE IMBALLO				
	Width	Depth	Height	Weight
	Larghezza	Profondità	Altezza	Peso
<b>cm</b>	114	91	72,5	<b>kg</b> 107
<b>inch</b>	45	35,8	28,5	<b>lbs</b> 236

Description		Code
Descrizione		Codice
<b>Chimney cap</b> Comignolo	<b>A</b>	CMG-1-012
<b>Chimney</b> Canna fumaria	<b>B</b>	TI150_480_SAT
<b>Door</b> Sportello	<b>C</b>	SPT-1-012
<b>Flange</b> Flangia	<b>D</b>	FLG-2-009
<b>External shell</b> Carter esterno	<b>E</b>	CRT-1-025
<b>Thermometer</b> Termometro	<b>F</b>	YT63-135
<b>Red bricks 30x20 cm</b> Mattoni 30x20 cm	<b>G</b>	RRA3020
<b>Feet (n.4)</b> Piedini	<b>H</b>	SETPIE-M10X20
<b>Logo Alfa (v1.0)</b>	<b>I</b>	D14PLAC-ALFA



# Moderno 3 Pizze

Data Sheets - Scheda Tecnica



**ANTIQUE RED**

FXMD-3-GROA

**ARDESIA GREY**

FXMD-3-GGRA

**FIRE YELLOW**

FXMD-3-GGIA

<b>Weight</b> Peso	<b>97 kg</b> <b>214 lbs</b>	<b>Materials</b> Materiali	<b>Stainless Steel, iron sheet, Ceramic fiber</b> Acciaio inox, lamiera ferro, Fibroceramica	
<b>Cooking floor</b> Piano Cottura	<b>80x50 cm</b> <b>31 x 20 in</b>	<b>Type of refractory</b> Tipo di refrattario	<b>Alumina silicate HeatKeeper™ Firebrick</b> Tavella HeatKeeper™ silico-alluminoso	
<b>Max oven temperature</b> Temperatura massima	<b>500°C</b> <b>1000°F</b>	<b>Recommended fuel</b> Combustibile consigliato	<b>LPG gas (G30 / G31)</b> Gas GPL (G30 / G31)	<b>Natural Gas (G20)</b> Gas Metano (G20)
<b>Heating time</b> Minuti per scaldare	<b>30'</b>	<b>Gas category</b> Categoria gas	<b>I3+ GPL</b>	<b>I2H (METANO)</b>
<b>Pizza capacity</b> Numero Pizze	<b>3 Pizza</b> Ø30cm	<b>Operation</b> Funzionamento	<b>28..30 / 37 mbar</b> 11 in WC	<b>20 mbar</b> 4 in WC
<b>Heat capacity</b> Potenza nominale	<b>18 kW</b> 61.418 Btu/h	<b>Max consumption</b> Consumo Massimo	<b>1.57 kg/h</b>	<b>2.07 m³/h</b>



*made in Italy*

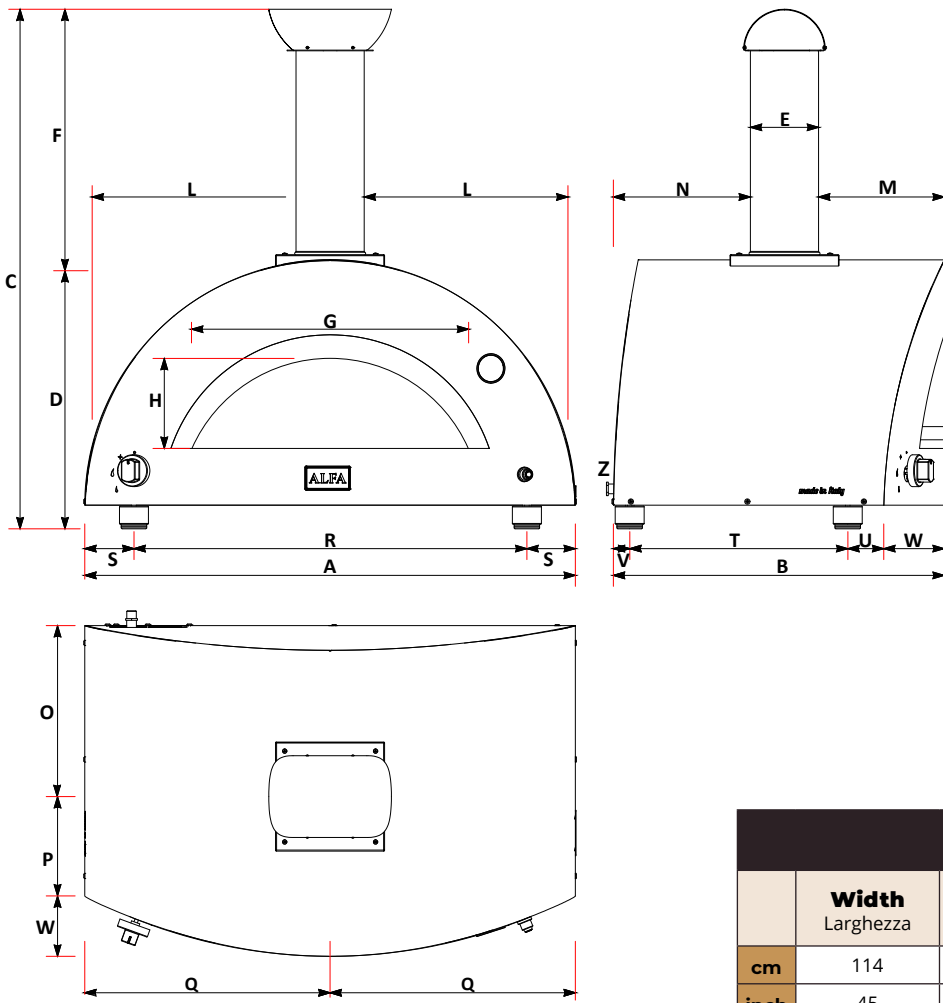

	cm	inch		cm	inch
<b>A</b>	108	42,5	<b>N</b>	30,1	11,9
<b>B</b>	72,8	28,7	<b>O</b>	37,6	14,8
<b>C</b>	114	44,9	<b>P</b>	21,9	8,6
<b>D</b>	60,3	23,7	<b>Q</b>	54	21,3
<b>E</b>	15 $\varnothing$	5,9	<b>R</b>	86,5	34,1
<b>F</b>	54	21,3	<b>S</b>	10,8	4,3
<b>G</b>	61	24,0	<b>T</b>	48	18,9
<b>H</b>	20	7,9	<b>U</b>	7,95	3,1
<b>L</b>	46,5	18,3	<b>V</b>	3,5	1,4
<b>M</b>	27,7	10,9	<b>W</b>	13,3	5,2

**A minimum of 10 cm (4 in) must be considered to connect the oven to the gas source.**

**Z** E' necessario prevedere un minimo di 10 cm per collegare il forno al gas.

PACKAGING				
DIMENSIONE IMBALLO				
	Width Larghezza	Depth Profondità	Height Altezza	Weight Peso
<b>cm</b>	114	91	72,5	<b>kg</b> 107
<b>inch</b>	45	35,8	28,5	<b>lbs</b> 236

Description Descrizione	Code Codice
<b>Chimney cap</b> Comignolo	<b>A</b> CMG-1-012
<b>Chimney</b> Canna fumaria	<b>B</b> TI150_480_SAT
<b>Door</b> Sportello	<b>C</b> SPT-1-012
<b>Flange</b> Flangia	<b>D</b> FLG-2-009
<b>External shell</b> Carter esterno	<b>E</b> CRT-1-018
<b>Thermometer</b> Termometro	<b>F</b> YT63-135
<b>Red bricks 30x20 cm</b> Mattoni 30x20 cm	<b>G</b> RRA3020
<b>Feet (n.4)</b> Piedini	<b>H</b> SETPIE-M10X20
<b>Logo Alfa (v1.0)</b>	<b>I</b> D14PLAC-ALFA
<b>KIT GAS 24kW</b>	<b>L</b> GAS-1-009
<b>Gas knob</b> Manopola gas	<b>M</b> D14MANO-70P
<b>Electric generator</b> Generatore elettrico	<b>N</b> GENELP003IQ
<b>Electrical cable</b> Cavo elettrico	<b>N</b> D14CAVOTV-1500
<b>Side gas cover</b> Carter laterale gas	<b>O</b> CRT-2-028



# Moderno 5 Pizze

Data Sheets - Scheda Tecnica



**ANTIQUE RED**  
FXMD-5-LROA

**ARDESIA GREY**  
FXMD-5-LGRA

**FIRE YELLOW**  
FXMD-5-LGIA

<b>Weight</b> Peso	<b>156 kg</b> <b>343 lbs</b>	<b>Materials</b> Materiali	<b>Stainless Steel, iron sheet, Ceramic fiber</b> Acciaio inox, lamiera ferro, Fibroceramica
<b>Cooking floor</b> Piano Cottura	<b>100x70 cm</b> <b>40 x 28 in</b>	<b>Type of refractory</b> Tipo di refrattario	<b>Alumina silicate HeatKeeper™ Firebrick</b> Tavella HeatKeeper™ silico-alluminoso
<b>Max oven temperature</b> Temperatura massima	<b>500°C</b> <b>1000°F</b>	<b>Recommended fuel</b> Combustibile consigliato	<b>WOOD - Max 2 in diam. logs. trimmings</b> LEGNA - Ciochi diametro Max 5 cm potature
<b>Heating time</b> Minuti per scaldare	<b>30'</b>	<b>Minimum flue draught</b> Tiraggio minimo	<b>11 Pa</b>
<b>Pizza capacity</b> Numero Pizze	<b>5</b> Ø30cm	<b>Flue smokes mass flow</b> Flusso volumetrico fumi	<b>49.6 g/s</b>
<b>Rated charge</b> Carica Nominale	<b>8.3 kg/h</b> 18.3 lbs/h	<b>Average consumption</b> Consumo Medio	<b>5 kg/h</b> 11 lbs/h
<b>Smoke temperature</b> Temperatura fumi	<b>395°C</b> 743°F	<b>CO emission at 13% O<sub>2</sub></b> Emissioni CO al 13% O <sub>2</sub>	<b>0.35% 4444 mg/Nm<sup>3</sup></b>



*made in Italy*

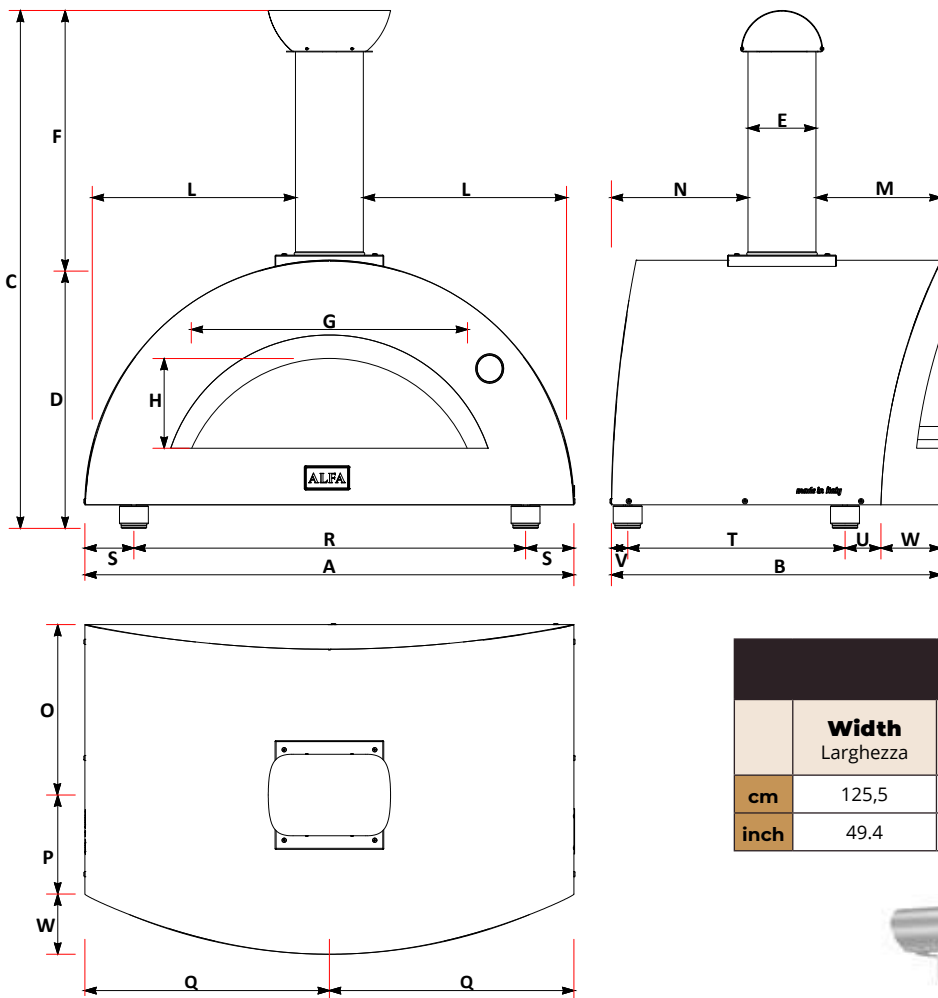

	cm	inch		cm	inch
<b>A</b>	118,3	46,6	<b>N</b>	60,5	23,8
<b>B</b>	102	40,2	<b>O</b>	69,5	27,4
<b>C</b>	149	58,7	<b>P</b>	32,5	12,8
<b>D</b>	64,7	25,5	<b>Q</b>	59,2	23,3
<b>E</b>	15 $\varnothing$	5,9	<b>R</b>	96	37,8
<b>F</b>	84,3	33,2	<b>S</b>	11,1	4,4
<b>G</b>	58	22,8	<b>T</b>	75	29,5
<b>H</b>	19,5	7,7	<b>U</b>	2,9	1,1
<b>L</b>	50,1	19,7	<b>V</b>	6,9	2,7
<b>M</b>	23,5	9,3	<b>W</b>	17,1	6,7

PACKAGING				
DIMENSIONE IMBALLO				
	Width Larghezza	Depth Profondità	Height Altezza	Weight Peso
<b>cm</b>	125,5	109,5	85	<b>kg</b> 201
<b>inch</b>	49.4	43.1	33.5	<b>lbs</b> 443

Description Descrizione	Code Codice
<b>Chimney cap</b> Comignolo	<b>A</b> S6PZ_01_025
<b>Chimney</b> Canna fumaria	<b>B</b> TI_180_750_SAT
<b>Door</b> Sportello	<b>C</b> S6PZ_01_021
<b>Flange</b> Flangia	<b>D</b> SML_03_0182
<b>External shell</b> Carter esterno	<b>E</b> SCRT-01-029
<b>Thermometer</b> Termometro	<b>F</b> YT63-135
<b>Red bricks 30x20 cm</b> Mattoni 30x20 cm	<b>G</b> RRA3020
<b>Red bricks 40x20 cm</b> Mattoni 40x20 cm	RRA4020
<b>Feet (n.4)</b> Piedini	<b>H</b> SETPIE-M10X20
<b>Logo Alfa (v1.0)</b>	<b>I</b> D14PLAC-ALFA



# Moderno 5 Pizze

Data Sheets - Scheda Tecnica



### ANTIQUE RED

FXMD-5-GROA

### ARDESIA GREY

FXMD-5-GGRA

### FIRE YELLOW

FXMD-5-GGIA

<b>Weight</b> Peso	<b>175 kg</b> <b>386 lbs</b>	<b>Materials</b> Materiali	<b>Stainless Steel, iron sheet, Ceramic fiber</b> Acciaio inox, lamiera ferro, Fibroceramica	
<b>Cooking floor</b> Piano Cottura	<b>80x50 cm</b> <b>34 x 28 in</b>	<b>Type of refractory</b> Tipo di refrattario	<b>Alumina silicate HeatKeeper™ Firebrick</b> Tavella HeatKeeper™ silico-alluminoso	
<b>Max oven temperature</b> Temperatura massima	<b>500°C</b> <b>1000°F</b>	<b>Recommended fuel</b> Combustibile consigliato	<b>LPG gas (G30 / G31)</b> Gas GPL (G30 / G31)	<b>Natural Gas (G20)</b> Gas Metano (G20)
<b>Heating time</b> Minuti per scaldare	<b>30'</b>	<b>Gas category</b> Categoria gas	<b>I3+ GPL</b>	<b>I2H (METANO)</b>
<b>Pizza capacity</b> Numero Pizze	<b>5</b> Ø30cm	<b>Operation</b> Funzionamento	<b>28..30 / 37 mbar</b> 11 in WC	<b>20 mbar</b> 4 in WC
<b>Heat capacity</b> Potenza nominale	<b>24 kW</b> 81.891 Btu/h	<b>Max consumption</b> Consumo Massimo	<b>2.1 kg/h</b>	<b>2 m³/h</b>



*made in Italy*

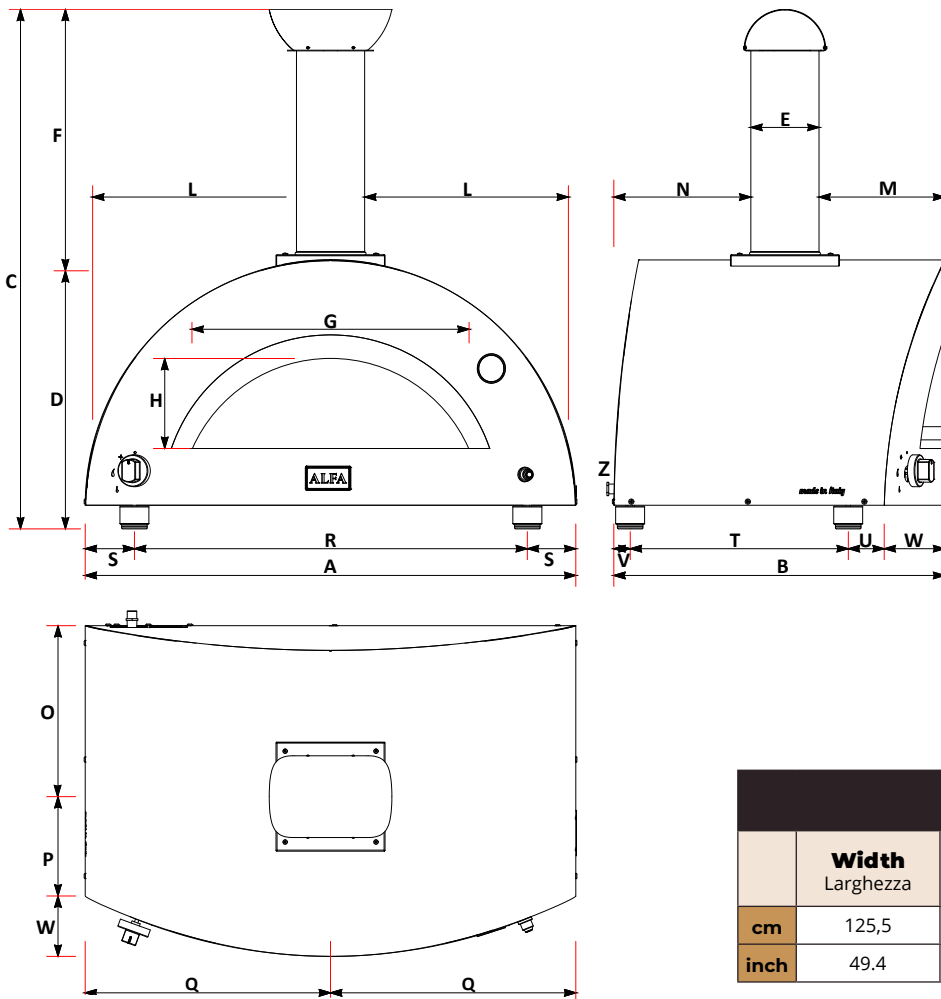

	cm	inch		cm	inch
<b>V</b>	118,3	46,6	<b>N</b>	60,5	23,8
<b>B</b>	102	40,2	<b>O</b>	69,5	27,4
<b>C</b>	149	58,7	<b>P</b>	32,5	12,8
<b>D</b>	64,7	25,5	<b>Q</b>	59,2	23,3
<b>E</b>	15	5,9	<b>R</b>	96	37,8
<b>F</b>	84,3	33,2	<b>S</b>	11,1	4,4
<b>G</b>	58	22,8	<b>T</b>	75	29,5
<b>H</b>	19,5	7,7	<b>U</b>	2,9	1,1
<b>L</b>	50,1	19,7	<b>V</b>	6,9	2,7
<b>M</b>	23,5	9,3	<b>W</b>	17,1	6,7

**Z** A minimum of 10 cm (4 in) must be considered to connect the oven to the gas source.  
E' necessario prevedere un minimo di 10 cm per collegare il forno al gas.

PACKAGING DIMENSIONE IMBALLO					
	Width Larghezza	Depth Profondità	Height Altezza	Weight Peso	
<b>cm</b>	125,5	109,5	85	<b>kg</b>	201
<b>inch</b>	49.4	43.1	33.5	<b>lbs</b>	443

Description Descrizione		Code Codice
<b>Chimney cap</b> Comignolo	<b>A</b>	SSML-1-9401
<b>Chimney</b> Canna fumaria	<b>B</b>	TI150_480_SAT
<b>Door</b> Sportello	<b>C</b>	6SPZ-01-0200-V2
<b>Flange</b> Flangia	<b>D</b>	FLG-2-016
<b>External shell</b> Carter esterno	<b>E</b>	CRT-1-020
<b>Thermometer</b> Termometro	<b>F</b>	YT63-190
<b>Red bricks 30x20 cm</b> Mattoni 30x20 cm	<b>G</b>	RRA3020
<b>Red bricks 40x20 cm</b> Mattoni 40x20 cm	<b>G</b>	RRA4020
<b>Feet (n.4)</b> Piedini	<b>H</b>	SETPIE-M10X20
<b>Logo Alfa (v1.0)</b>	<b>I</b>	D14PLAC-ALFA
<b>KIT GAS 24kW</b>	<b>L</b>	GAS-1-014
<b>Gas knob</b> Manopola gas	<b>M</b>	D14MANO-70P
<b>Electric generator</b> Generatore elettrico	<b>N</b>	GENELP003IQ
<b>Electrical cable</b> Cavo elettrico	<b>N</b>	D14CAVOTV-1500
<b>Side gas cover</b> Carter laterale gas	<b>O</b>	CRT-2-042



# Classico 2 Pizze

Data Sheets - Scheda Tecnica



**ARDESIA GREY**  
FXCL-2-LGRA

<b>Weight</b> Peso	<b>86 kg</b> <b>189 lbs</b>	<b>Materials</b> Materiali	<b>Stainless Steel, iron sheet, Ceramic fiber</b> Acciaio inox, lamiera ferro, Fibroceramica
<b>Cooking floor</b> Piano Cottura	<b>70x50 cm</b> <b>28 x 20 in</b>	<b>Type of refractory</b> Tipo di refrattario	<b>Alumina silicate HeatKeeper™ Firebrick</b> Tavella HeatKeeper™ silico-alluminoso
<b>Max oven temperature</b> Temperatura massima	<b>500°C</b> <b>1000°F</b>	<b>Recommended fuel</b> Combustibile consigliato	<b>WOOD - Max 2 in diam. logs. trimmings</b> LEGNA - Ciochi diametro Max 5 cm potature
<b>Heating time</b> Minuti per scaldare	<b>30'</b>	<b>Minimum flue draught</b> Tiraggio minimo	<b>10 Pa</b>
<b>Pizza capacity</b> Numero Pizze	<b>2 Pizza</b> Ø30cm	<b>Flue smokes mass flow</b> Flusso volumetrico fumi	<b>57.7 g/s</b>
<b>Rated charge</b> Carica Nominale	<b>6.9 kg/h</b> 15,2 lbs/h	<b>Average consumption</b> Consumo Medio	<b>1.6 kg/h</b> 3.5 lbs/h
<b>Smoke temperature</b> Temperatura fumi	<b>395°C</b> 743°F	<b>CO emission at 13% O<sub>2</sub></b> Emissioni CO al 13% O <sub>2</sub>	<b>0.31% 3843 mg/Nm<sup>3</sup></b>



*made in Italy*



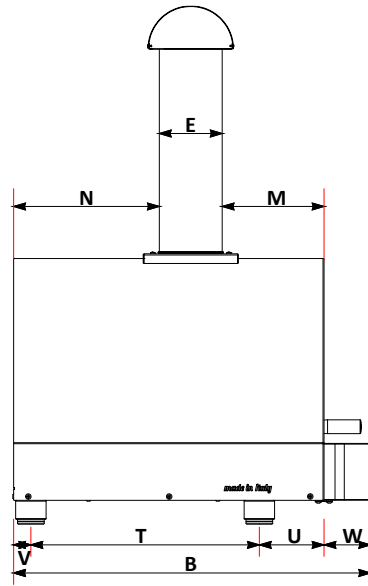
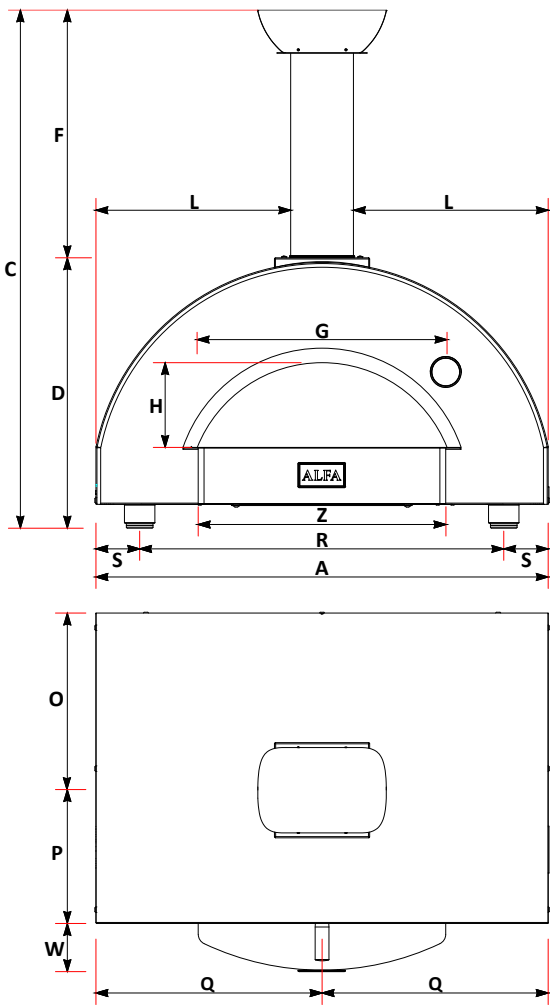

	cm	inch		cm	inch
A	95	37,4	O	36,9	14,5
B	75	29,5	P	28,3	11,1
C	109	42,9	Q	47,5	18,7
D	51,8	20,4	R	76,5	30,1
E	13,2	5,2	S	9,2	3,6
F	52,1	20,5	T	48	18,9
G	52,5	20,7	U	13,6	5,4
H	17,85	7,0	V	3,6	1,4
L	40,1	15,8	W	9,8	3,9
M	21,4	8,4	Z	52	20,5
N	30,6	12,0			

PACKAGING				
DIMENSIONE IMBALLO				
	Width Larghezza	Depth Profondità	Height Altezza	Weight Peso
cm	101,5	86	68,5	kg 96
inch	40	34	27	lbs 212

Description Descrizione	Code Codice
<b>Chimney cap</b> Comignolo	<b>A</b> CMG-1-009
<b>Chimney</b> Canna fumaria	<b>B</b> TI130_480_SAT
<b>Door</b> Sportello	<b>C</b> SPT-1-010
<b>Flange</b> Flangia	<b>D</b> FLG-2-008
<b>External shell</b> Carter esterno	<b>E</b> CRT-1-023
<b>Thermometer</b> Termometro	<b>F</b> YT63-135
<b>Red bricks 30x20 cm</b> Mattoni 30x20 cm	<b>G</b> RRA3020
<b>Feet (n.4)</b> Piedini	<b>H</b> SETPIE-M10X20
<b>Logo Alfa (v1.0)</b>	<b>I</b> D14PLAC-ALFA



# Classico 2 Pizze

Data Sheets - Scheda Tecnica



## ARDESIA GREY

FXCL-2-GGRA

<b>Weight</b> Peso	<b>86 kg</b> <b>189 lbs</b>	<b>Materials</b> Materiali	<b>Stainless Steel, iron sheet, Ceramic fiber</b> Acciaio inox, lamiera ferro, Fibroceramica	
<b>Cooking floor</b> Piano Cottura	<b>60x50 cm</b> <b>24 x 20 in</b>	<b>Type of refractory</b> Tipo di refrattario	<b>Alumina silicate HeatKeeper™ Firebrick</b> Tavella HeatKeeper™ silico-alluminoso	
<b>Max oven temperature</b> Temperatura massima	<b>500°C</b> <b>1000°F</b>	<b>Recommended fuel</b> Combustibile consigliato	<b>LPG gas (G30 / G31)</b> Gas GPL (G30 / G31)	<b>Natural Gas (G20)</b> Gas Metano (G20)
<b>Heating time</b> Minuti per scaldare	<b>30'</b>	<b>Gas category</b> Categoria gas	<b>I3+ GPL</b>	<b>I2H (METANO)</b>
<b>Pizza capacity</b> Numero Pizze	<b>2 Pizza</b> Ø30cm	<b>Operation</b> Funzionamento	<b>28..30 / 37 mbar</b> 11 in WC	<b>20 mbar</b> 4 in WC
<b>Heat capacity</b> Potenza nominale	<b>15 kW</b> 51.182 BTU/h	<b>Max consumption</b> Consumo Massimo	<b>0.96 kg/h</b>	<b>1.54 m³/h</b>



*made in Italy*

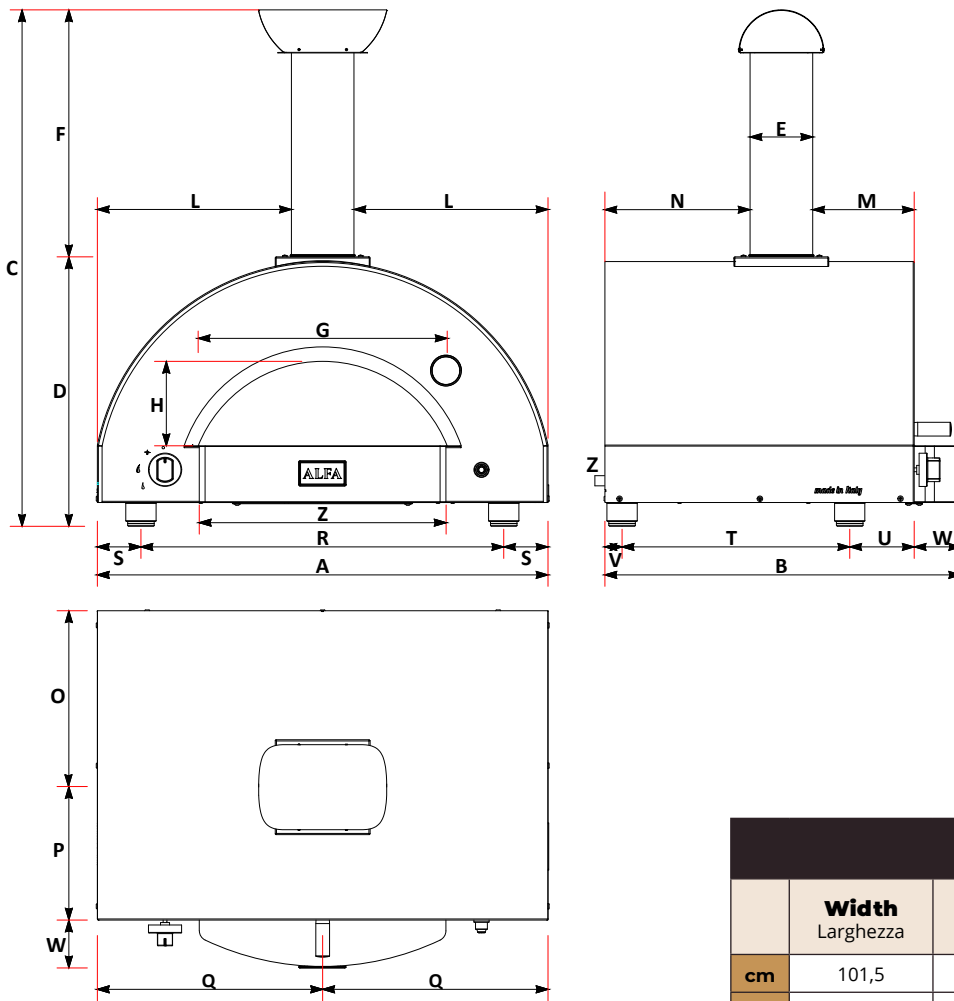

	cm	inch		cm	inch
A	95	37,4	O	36,9	14,5
B	75	29,5	P	28,3	11,1
C	109	42,9	Q	47,5	18,7
D	51,8	20,4	R	76,5	30,1
E	13,2	5,2	S	9,2	3,6
F	52,1	20,5	T	48	18,9
G	52,5	20,7	U	13,6	5,4
H	17,85	7,0	V	3,6	1,4
L	40,1	15,8	W	9,8	3,9
M	21,4	8,4	Z	52	20,5
N	30,6	12,0			

**Z** A minimum of 10 cm (4 in) must be considered to connect the oven to the gas source.  
 E' necessario prevedere un minimo di 10 cm per collegare il forno al gas.

PACKAGING DIMENSIONE IMBALLO				
	Width Larghezza	Depth Profondità	Height Altezza	Weight Peso
cm	101,5	86	68,5	kg 96
inch	40	34	27	lbs 212

Description Descrizione	Code Codice
<b>Chimney cap</b> Comignolo	<b>A</b> CMG-1-009
<b>Chimney</b> Canna fumaria	<b>B</b> TI130_480_SAT
<b>Door</b> Sportello	<b>C</b> SPT-1-010
<b>Flange</b> Flangia	<b>D</b> FLG-2-008
<b>External shell</b> Carter esterno	<b>E</b> CRT-1-003
<b>Thermometer</b> Termometro	<b>F</b> YT63-135
<b>Red bricks 30x20 cm</b> Mattoni 30x20 cm	<b>G</b> RRA3020
<b>Feet (n.4)</b> Piedini	<b>H</b> SETPIE-M10X20
<b>Logo Alfa (v1.0)</b>	<b>I</b> D14PLAC-ALFA
<b>KIT GAS 24kW</b>	<b>L</b> GAS-1-016
<b>Gas knob</b> Manopola gas	<b>M</b> D14MANO-70P
<b>Electric generator</b> Generatore elettrico	<b>N</b> GENELP003IQ
<b>Electrical cable</b> Cavo elettrico	<b>N</b> D14CAVOTV-1500
<b>Side gas cover</b> Carter laterale gas	<b>O</b> CRT-2-049



# Classico 4 Pizze

Data Sheets - Scheda Tecnica



## ARDESIA GREY FXCL-4-LGRA

<b>Weight</b> Peso	<b>118 kg</b> <b>260 lbs</b>	<b>Materials</b> Materiali	<b>Stainless Steel, iron sheet, Ceramic fiber</b> Acciaio inox, lamiera ferro, Fibrocaramica
<b>Cooking floor</b> Piano Cottura	<b>90 x 60 cm</b> <b>35 x 24 in</b>	<b>Type of refractory</b> Tipo di refrattario	<b>Alumina silicate HeatKeeper™ Firebrick</b> Tavella HeatKeeper™ silico-alluminoso
<b>Max oven temperature</b> Temperatura massima	<b>500°C</b> <b>1000°F</b>	<b>Recommended fuel</b> Combustibile consigliato	<b>WOOD - Max 2 in diam. logs. trimmings</b> LEGNA - Ciochi diametro Max 5 cm potature
<b>Heating time</b> Minuti per scaldare	<b>30'</b>	<b>Minimum flue draught</b> Tiraggio minimo	<b>11 Pa</b>
<b>Pizza capacity</b> Numero Pizze	<b>4 Pizza</b> Ø30cm	<b>Flue smokes mass flow</b> Flusso volumetrico fumi	<b>49.6 g/s</b>
<b>Rated charge</b> Carica Nominale	<b>8.3 kg/h</b> 18.3 lbs/h	<b>Average consumption</b> Consumo Medio	<b>2.4 kg/h</b> 5.2 lbs/h
<b>Smoke temperature</b> Temperatura fumi	<b>400°C</b> 752°F	<b>CO emission at 13% O<sub>2</sub></b> Emissioni CO al 13% O <sub>2</sub>	<b>0.35% 4444 mg/Nm<sup>3</sup></b>



*made in Italy*

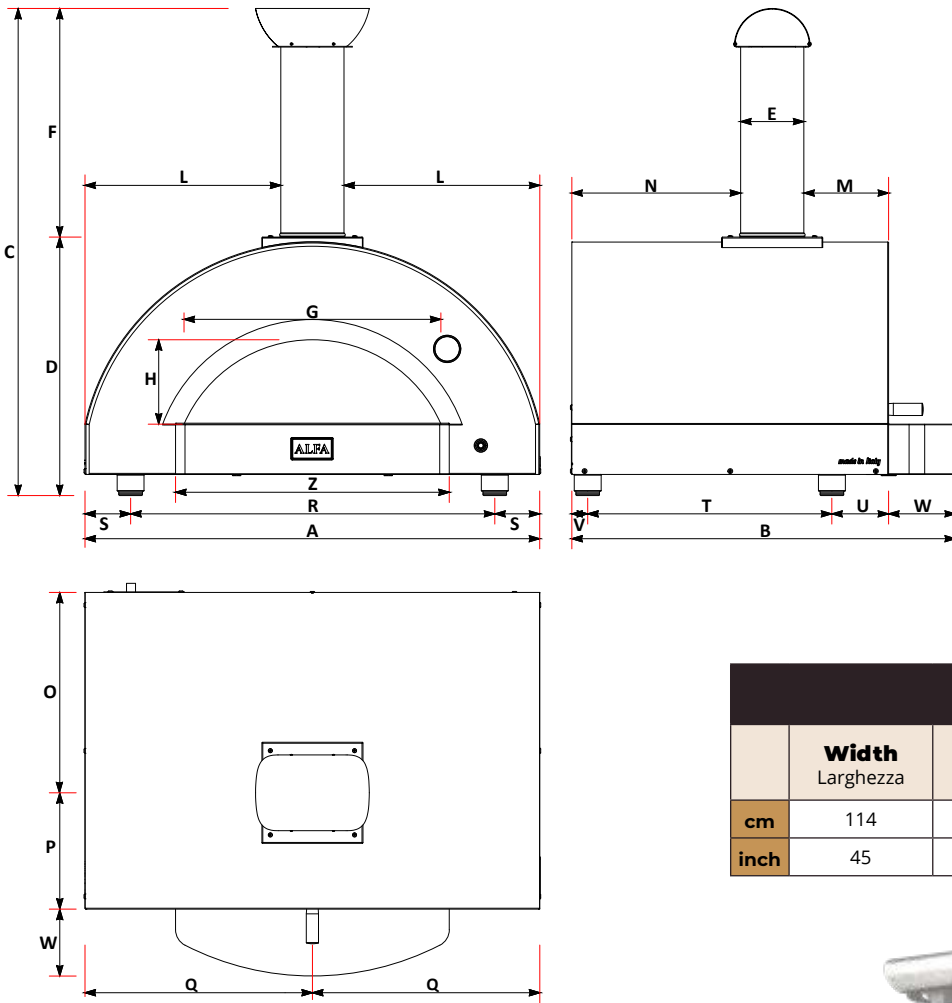

	cm	inch		cm	inch
A	108	42,5	O	47,6	18,7
B	91	35,8	P	27,6	10,9
C	115,7	45,6	Q	54	21,3
D	56,4	22,2	R	86,5	34,1
E	15 $\varnothing$	5,9	S	10,8	4,3
F	54,2	21,3	T	58	22,8
G	61	24,0	U	13,5	5,3
H	20	7,9	V	3,8	1,5
L	46,5	18,3	W	15,9	6,3
M	20,1	7,9	Z	65	25,6
N	39,9	15,7			

PACKAGING				
DIMENSIONE IMBALLO				
	Width Larghezza	Depth Profondità	Height Altezza	Weight Peso
cm	114	101	72,5	kg 128
inch	45	39,8	28,5	lbs 282

Description Descrizione	Code Codice
<b>Chimney cap</b> Comignolo	<b>A</b> CMG-1-008
<b>Chimney</b> Canna fumaria	<b>B</b> TI150_480_SAT
<b>Door</b> Sportello	<b>C</b> SPT-1-008
<b>Flange</b> Flangia	<b>D</b> FLG-2-007
<b>External shell</b> Carter esterno	<b>E</b> CRT-1-024
<b>Thermometer</b> Termometro	<b>F</b> YT63-135
<b>Red bricks 30x20 cm</b> Mattoni 30x20 cm	<b>G</b> RRA3020
<b>Feet (n.4)</b> Piedini	<b>H</b> SETPIE-M10X20
<b>Logo Alfa (v1.0)</b>	<b>I</b> D14PLAC-ALFA



# Classico 4 Pizze

Data Sheets - Scheda Tecnica



## ARDESIA GREY

FXCL-2-GGRA

<b>Weight</b> Peso	<b>118 kg</b> <b>260 lbs</b>	<b>Materials</b> Materiali	<b>Stainless Steel, iron sheet, Ceramic fiber</b> Acciaio inox, lamiera ferro, Fibroceramica	
<b>Cooking floor</b> Piano Cottura	<b>80x60 cm</b> <b>31 x 24 in</b>	<b>Type of refractory</b> Tipo di refrattario	<b>Alumina silicate HeatKeeper™ Firebrick</b> Tavella HeatKeeper™ silico-alluminoso	
<b>Max oven temperature</b> Temperatura massima	<b>500°C</b> <b>1000°F</b>	<b>Recommended fuel</b> Combustibile consigliato	<b>LPG gas (G30 / G31)</b> Gas GPL (G30 / G31)	<b>Natural Gas (G20)</b> Gas Metano (G20)
<b>Heating time</b> Minuti per scaldare	<b>30'</b>	<b>Gas category</b> Categoria gas	<b>I3+ GPL</b>	<b>I2H (METANO)</b>
<b>Pizza capacity</b> Numero Pizze	<b>4 Pizza</b> Ø30cm	<b>Operation</b> Funzionamento	<b>28..30 / 37 mbar</b> 11 in WC	<b>20 mbar</b> 4 in WC
<b>Heat capacity</b> Potenza nominale	<b>25 kW</b> 85.303 Btu/h	<b>Max consumption</b> Consumo Massimo	<b>1.94 kg/h</b>	<b>3.29 m³/h</b>



*made in Italy*

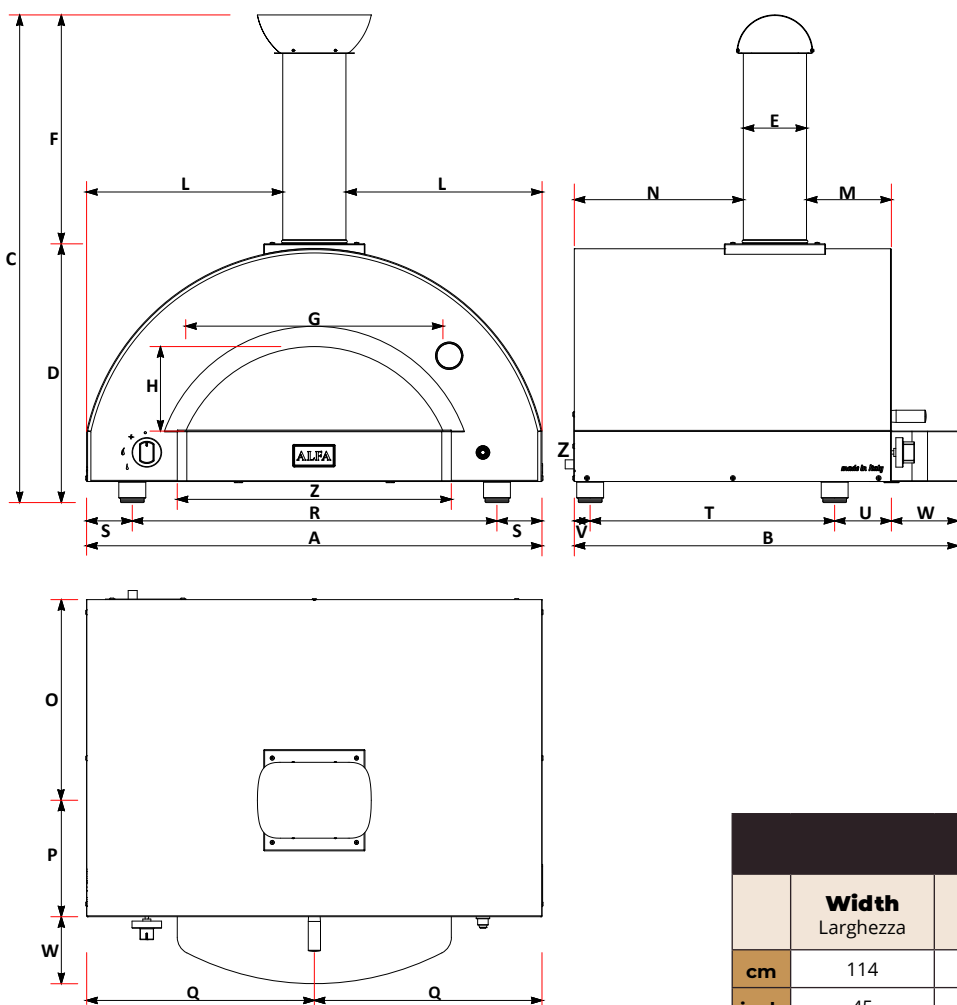

	cm	inch		cm	inch
<b>A</b>	108	42,5	<b>O</b>	47,6	18,7
<b>B</b>	91	35,8	<b>P</b>	27,6	10,9
<b>C</b>	115,7	45,6	<b>Q</b>	54	21,3
<b>D</b>	56,4	22,2	<b>R</b>	86,5	34,1
<b>E</b>	15	5,9	<b>S</b>	10,8	4,3
<b>F</b>	54,2	21,3	<b>T</b>	58	22,8
<b>G</b>	61	24,0	<b>U</b>	13,5	5,3
<b>H</b>	20	7,9	<b>V</b>	3,8	1,5
<b>L</b>	46,5	18,3	<b>W</b>	15,9	6,3
<b>M</b>	20,1	7,9	<b>Z</b>	65	25,6
<b>N</b>	39,9	15,7			

**Z** A minimum of 10 cm (4 in) must be considered to connect the oven to the gas source.  
 E' necessario prevedere un minimo di 10 cm per collegare il forno al gas.

PACKAGING				
DIMENSIONE IMBALLO				
	Width Larghezza	Depth Profondità	Height Altezza	Weight Peso
<b>cm</b>	114	101	72,5	<b>kg</b> 128
<b>inch</b>	45	39,8	28,5	<b>lbs</b> 282

Description Descrizione		Code Codice
<b>Chimney cap</b> Comignolo	<b>A</b>	CMG-1-008
<b>Chimney</b> Canna fumaria	<b>B</b>	TI150_480_SAT
<b>Door</b> Sportello	<b>C</b>	SPT-1-008
<b>Flange</b> Flangia	<b>D</b>	FLG-2-007
<b>External shell</b> Carter esterno	<b>E</b>	CRT-1-004
<b>Thermometer</b> Termometro	<b>F</b>	YT63-135
<b>Red bricks 30x20 cm</b> Mattoni 30x20 cm	<b>G</b>	RRA3020
<b>Feet (n.4)</b> Piedini	<b>H</b>	SETPIE-M10X20
<b>Logo Alfa (v1.0)</b>	<b>I</b>	D14PLAC-ALFA
<b>KIT GAS 24kW</b>	<b>L</b>	GAS-1-008
<b>Gas knob</b> Manopola gas	<b>M</b>	D14MANO-70P
<b>Electric generator</b> Generatore elettrico	<b>N</b>	GENELP003IQ
<b>Electrical cable</b> Cavo elettrico	<b>N</b>	D14CAVOTV-1500
<b>Side gas cover</b> Carter laterale gas	<b>O</b>	CRT-2-052



# Futuro 2 Pizze

Data Sheets - Scheda Tecnica



## SILVER BLACK

FXFT-2P-GGRA

<b>Weight</b> Peso	<b>110 kg</b> <b>242 lbs</b>	<b>Materials</b> Materiali	<b>Stainless Steel, iron sheet, Ceramic fiber</b> Acciaio inox, lamiera ferro, Fibroceramica	
<b>Cooking floor</b> Piano Cottura	<b>70x40 cm</b> <b>27.5 x 15.7 in</b>	<b>Type of refractory</b> Tipo di refrattario	<b>Alumina silicate HeatKeeper™ Firebrick</b> Tavella HeatKeeper™ silico-alluminoso	
<b>Max oven temperature</b> Temperatura massima	<b>500°C</b> <b>1000°F</b>	<b>Recommended fuel</b> Combustibile consigliato	<b>LPG gas (G30 / G31)</b> Gas GPL (G30 / G31)	<b>Natural Gas (G20)</b> Gas Metano (G20)
<b>Heating time</b> Minuti per scaldare	<b>30'</b>	<b>Gas category</b> Categoria gas	<b>I3+ GPL</b>	<b>I2H (METANO)</b>
<b>Pizza capacity</b> Numero Pizze	<b>2 Pizza</b> Ø 30cm	<b>Operation</b> Funzionamento	<b>28..30 / 37 mbar</b> 11 in WC	<b>20 mbar</b> 4 in WC
<b>Heat capacity</b> Potenza nominale	<b>15 kW</b> 70.000 Btu/h	<b>Max consumption</b> Consumo Massimo	<b>1.07 / 1.09 kg/h</b>	<b>1.43 m³/h</b>



*made in Italy*



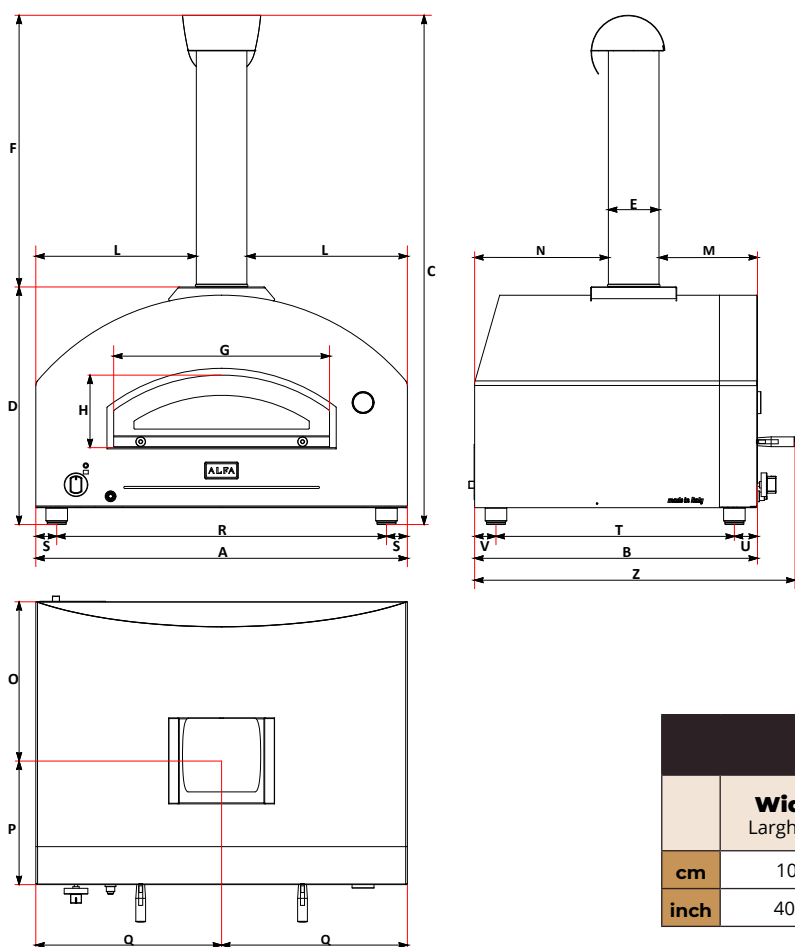

	cm	inch		cm	inch
<b>A</b>	100	39.3	<b>N</b>	25.7	10.1
<b>B</b>	69.7	27.4	<b>O</b>	31.4	12.4
<b>C</b>	123.1	48.5	<b>P</b>	32.2	12.7
<b>D</b>	63	24.8	<b>Q</b>	50	19.7
<b>E</b>	13	5.1	<b>R</b>	87.8	34.6
<b>F</b>	55	21.7	<b>S</b>	6.2	2.4
<b>G</b>	54	21.3	<b>T</b>	50.7	20
<b>H</b>	20.8	8.2	<b>U</b>	12.6	5
<b>L</b>	43.6	17.2	<b>V</b>	6.3	2.5
<b>M</b>	25.2	9.9	<b>Z</b>	75	29.6

PACKAGING DIMENSIONE IMBALLO					
	Width Larghezza	Depth Profondità	Height Altezza	Weight Peso	
<b>cm</b>	104	76	80	<b>kg</b>	130
<b>inch</b>	40,5	29,6	31,2	<b>lbs</b>	286

Description Descrizione		Code Codice
<b>Chimney cap</b> Comignolo	<b>A</b>	SSML-1-2202
<b>Chimney</b> Canna fumaria	<b>B</b>	TI130_500_SAT
<b>Door</b> Sportello	<b>C</b>	SSML-1-2203
<b>Flange</b> Flangia	<b>D</b>	SML-2-2205
<b>External shell</b> Carter esterno	<b>E</b>	SCRT-1-2201-SB
<b>Thermometer</b> Termometro	<b>F</b>	YT63-135
<b>Red bricks 30x20 cm</b> Mattoni 30x20 cm	<b>G</b>	RRA3020 RRA4020
<b>Feet (n.4)</b> Piedini	<b>H</b>	SETPIE-M10X20
<b>Logo Alfa (v1.0)</b>	<b>I</b>	D14PLAC-ALFA
<b>KIT GAS 24kW</b>	<b>L</b>	SALI-1-2201
<b>Gas knob</b> Manopola gas	<b>M</b>	D14MANO-70P
<b>Electric generator</b> Generatore elettrico	<b>N</b>	GENELP003IQ
<b>Electrical cable</b> Cavo elettrico	<b>N</b>	CAVO-AT
<b>Side gas cover</b> Carter laterale gas	<b>O</b>	SCRT-3-2204-SB



# Futuro 4 Pizze

Data Sheets - Scheda Tecnica



## SILVER BLACK

FXFT-4P-GGRA

<b>Weight</b> Peso	<b>142 kg</b> <b>312 lbs</b>	<b>Materials</b> Materiali	<b>Stainless Steel, iron sheet, Ceramic fiber</b> Acciaio inox, lamiera ferro, Fibroceramica	
<b>Cooking floor</b> Piano Cottura	<b>80x60 cm</b> <b>31.5 x 23.6 in</b>	<b>Type of refractory</b> Tipo di refrattario	<b>Alumina silicate HeatKeeper™ Firebrick</b> Tavella HeatKeeper™ silico-alluminoso	
<b>Max oven temperature</b> Temperatura massima	<b>500°C</b> <b>1000°F</b>	<b>Recommended fuel</b> Combustibile consigliato	<b>LPG gas (G30 / G31)</b> Gas GPL (G30 / G31)	<b>Natural Gas (G20)</b> Gas Metano (G20)
<b>Heating time</b> Minuti per scaldare	<b>30'</b>	<b>Gas category</b> Categoria gas	<b>I3+ GPL</b>	<b>I2H (METANO)</b>
<b>Pizza capacity</b> Numero Pizze	<b>4 Pizza</b> Ø 30cm	<b>Operation</b> Funzionamento	<b>28..30 / 37 mbar</b> 11 in WC	<b>20 mbar</b> 4 in WC
<b>Heat capacity</b> Potenza nominale	<b>24 kW</b> 83.000 Btu/h	<b>Max consumption</b> Consumo Massimo	<b>1.35 / 1.32 kg/h</b>	<b>1.76 m³/h</b>



*made in Italy*

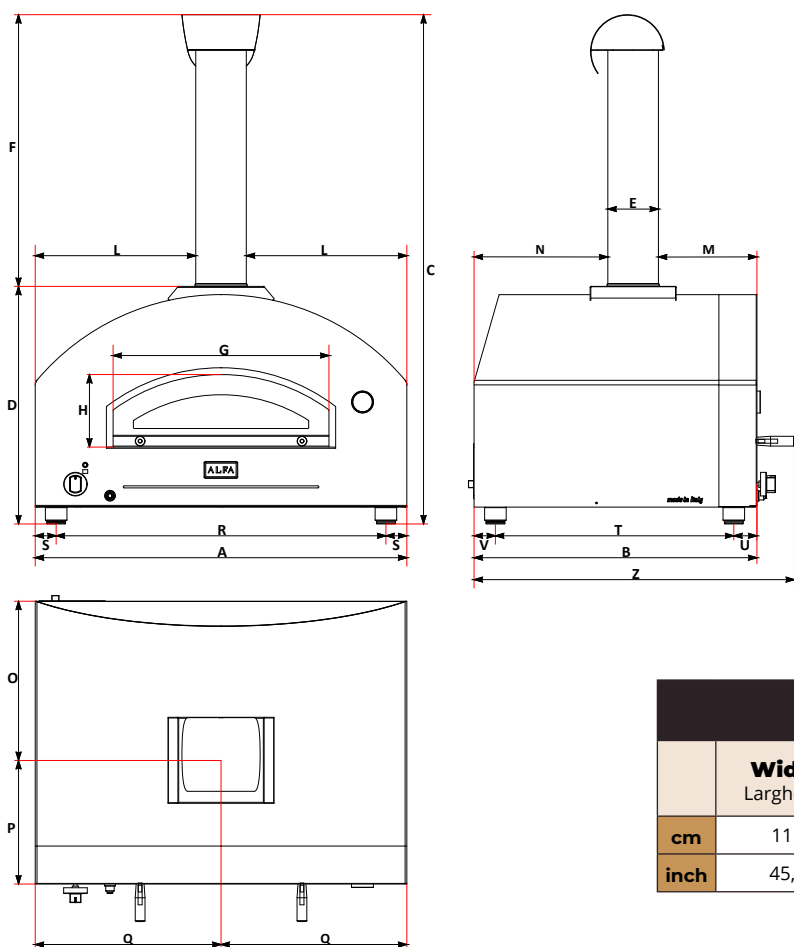

	cm	inch		cm	inch
<b>A</b>	110.2	43.4	<b>N</b>	39.7	15.6
<b>B</b>	89.4	35.2	<b>O</b>	47.2	18.6
<b>C</b>	151	59.4	<b>P</b>	39.7	15.6
<b>D</b>	65.4	25.7	<b>Q</b>	55.6	21.9
<b>E</b>	15	5.9	<b>R</b>	97.8	38.5
<b>F</b>	80.5	31.7	<b>S</b>	6.2	2.4
<b>G</b>	63.8	25.1	<b>T</b>	70.7	27.8
<b>H</b>	21.5	8.5	<b>U</b>	12.3	4.8
<b>L</b>	47.6	18.7	<b>V</b>	6.3	2.5
<b>M</b>	29.2	11.5	<b>Z</b>	95	37.4

PACKAGING				
DIMENSIONE IMBALLO				
	Width Larghezza	Depth Profondità	Height Altezza	Weight Peso
<b>cm</b>	115	93	82	<b>kg</b> 151
<b>inch</b>	45,3	36,6	32	<b>lbs</b> 332

Description Descrizione	Code Codice
<b>Chimney cap</b> Comignolo	<b>A</b> SSML-1-2302
<b>Chimney</b> Canna fumaria	<b>B</b> TI150_750_SAT
<b>Door</b> Sportello	<b>C</b> SSML-1-2301
<b>Flange</b> Flangia	<b>D</b> SML-2-2301
<b>External shell</b> Carter esterno	<b>E</b> SCRT-1-2201-SB
<b>Thermometer</b> Termometro	<b>F</b> YT63-135
<b>Red bricks 30x20 cm</b> Mattoni 30x20 cm	<b>G</b> RRA3020
<b>Feet (n.4)</b> Piedini	<b>H</b> SETPIE-M10X20
<b>Logo Alfa (v1.0)</b>	<b>I</b> D14PLAC-ALFA
<b>KIT GAS 24kW</b>	<b>L</b> SALI-1-2301
<b>Gas knob</b> Manopola gas	<b>M</b> D14MANO-70P
<b>Electric generator</b> Generatore elettrico	<b>N</b> GENELP003IQ
<b>Electrical cable</b> Cavo elettrico	<b>N</b> CAVO-AT
<b>Side gas cover</b> Carter laterale gas	<b>O</b> SCRT-3-2305-SB



**По вопросам продаж и поддержки обращайтесь:**

Алматы (7273)495-231  
Ангарск (3955)60-70-56  
Архангельск (8182)63-90-72  
Астрахань (8512)99-46-04  
Барнаул (3852)73-04-60  
Белгород (4722)40-23-64  
Благовещенск (4162)22-76-07  
Брянск (4832)59-03-52  
Владивосток (423)249-28-31  
Владикавказ (8672)28-90-48  
Владимир (4922)49-43-18  
Волгоград (844)278-03-48  
Вологда (8172)26-41-59  
Воронеж (473)204-51-73  
Екатеринбург (343)384-55-89  
Иваново (4932)77-34-06  
Ижевск (3412)26-03-58  
Иркутск (395)279-98-46  
Казань (843)206-01-48  
Россия +7(495)268-04-70

Калининград (4012)72-03-81  
Калуга (4842)92-23-67  
Кемерово (3842)65-04-62  
Киров (8332)68-02-04  
Коломна (4966)23-41-49  
Кострома (4942)77-07-48  
Краснодар (861)203-40-90  
Красноярск (391)204-63-61  
Курск (4712)77-13-04  
Курган (3522)50-90-47  
Липецк (4742)52-20-81  
Магнитогорск (3519)55-03-13  
Москва (495)268-04-70  
Мурманск (8152)59-64-93  
Набережные Челны (8552)20-53-41  
Нижний Новгород (831)429-08-12  
Новокузнецк (3843)20-46-81  
Ноябрьск (3496)41-32-12  
Новосибирск (383)227-86-73  
Киргизия +996(312)-96-26-47

Омск (3812)21-46-40  
Орел (4862)44-53-42  
Оренбург (3532)37-68-04  
Пенза (8412)22-31-16  
Петрозаводск (8142)55-98-37  
Псков (8112)59-10-37  
Пермь (342)205-81-47  
Ростов-на-Дону (863)308-18-15  
Рязань (4912)46-61-64  
Самара (846)206-03-16  
Саранск (8342)22-96-24  
Санкт-Петербург (812)309-46-40  
Саратов (845)249-38-78  
Севастополь (8692)22-31-93  
Симферополь (3652)67-13-56  
Смоленск (4812)29-41-54  
Сочи (862)225-72-31  
Ставрополь (8652)20-65-13  
Сургут (3462)77-98-35  
Казахстан +7(7172)727-132

Сыктывкар (8212)25-95-17  
Тамбов (4752)50-40-97  
Тверь (4822)63-31-35  
Тольятти (8482)63-91-07  
Томск (3822)98-41-53  
Тула (4872)33-79-87  
Тюмень (3452)66-21-18  
Ульяновск (8422)24-23-59  
Улан-Удэ (3012)59-97-51  
Уфа (347)229-48-12  
Хабаровск (4212)92-98-04  
Чебоксары (8352)28-53-07  
Челябинск (351)202-03-61  
Череповец (8202)49-02-64  
Чита (3022)38-34-83  
Якутск (4112)23-90-97  
Ярославль (4852)69-52-93